

川崎重工業株式会社

精密機械カンパニー

東京本社

〒105-8315 東京都港区海岸1丁目14-5
Tel. 03-3435-6862 Fax. 03-3435-2023

神戸本社

〒650-8680 神戸市中央区東川崎町1丁目1-3(神戸クリスタルタワー)
Tel. 078-360-8605 Fax. 078-360-8609

西神戸工場

〒651-2239 神戸市西区榑谷町松本234番地
Tel. 078-991-1133 Fax. 078-991-3186

福岡営業所

〒812-0011 福岡市博多区博多駅前1丁目4-1(博多駅前第一生命ビルディング9F)
Tel. 092-432-9561 Fax. 092-432-9566

東京サービスセンター

〒272-0015 千葉県市川市鬼高4丁目9-2
Tel. 047-379-8181 Fax. 047-379-8186

今治サービスセンター

〒794-0028 愛媛県今治市北宝来町1丁目5-3(ジブラルタ生命ビル、川重商事内)
Tel. 0898-22-2531 Fax. 0898-22-2183

福岡サービスセンター

〒811-0112 福岡県粕屋郡新宮町下府2丁目10-17
Tel. 092-963-0452 Fax. 092-963-2755

<http://www.khi.co.jp/kpm/>

Kawasaki Heavy Industries, Ltd.

Precision Machinery Company

<http://www.khi.co.jp/kpm/>

Tokyo Head Office

1-14-5 Kaigan, Minato-ku, Tokyo 105-8315, Japan
Phone +81-3-3435-6862 Fax. +81-3-3435-2023

Kobe Head Office

Kobe Crystal Tower, 1-3 Higashikawasaki-cho 1-chome, Chuo-ku, Kobe 650-8680, Japan
Phone +81-78-360-8607 Fax. +81-78-360-8609

Nishi-kobe Works

234, Matsumoto, Hasetani-cho, Nishi-ku, Kobe 651-2239, Japan
Phone +81-78-991-1160 Fax. +81-78-991-3186

OVERSEAS SUBSIDIARIES

Kawasaki Precision Machinery (UK) Ltd.

Ernesettle Lane, Ernesettle, Plymouth, Devon, PL5 2SA United Kingdom
Phone +44-1752-364394 Fax. +44-1752-364816
<http://www.kpm-eu.com>

Kawasaki Precision Machinery (U.S.A.), Inc.

3838 Broadmoor Avenue S.E. Grand Rapids, Michigan 49512, U.S.A.
Phone +1-616-975-3100 Fax. +1-616-975-3103
<http://www.kpm-usa.com>

Kawasaki Precision Machinery (Suzhou) Ltd.

668 JianLin Rd, New District, Suzhou, 215151 China
Phone +86-512-6616-0365 Fax. +86-512-6616-0366

Kawasaki Precision Machinery Trading (Shanghai) Co., Ltd.

17th Floor (Room 1701), The Headquarters Building, No168, XiZang Road (M), Huangpu District, Shanghai, 200001, China
Phone +86-21-3366-3800 Fax. +86-21-3366-3808

Kawasaki Chunhui Precision Machinery (Zhejiang) Ltd.

No.200 Yasha Road Shangyu Economic Development Zone, Shansyu, Zhejiang, 312300, China
Phone +86-575-8215-6999 Fax. +86-575-8215-8699

Flutek, Ltd.

98 GIL 6, Gongdan-Ro, Seongsan-Ku, Changwon-Si, Kyungnam, 641-370, Korea
Phone +82-55-210-5900 Fax. +82-55-286-5557

Wipro Kawasaki Precision Machinery Private Limited

No. 15, Sy. No. 35 & 37, Kumbalgodu Industrial Area, Kumbalgodu Village, Kengeri Hobli, Bangalore, - 560074, India

このカタログに記載の内容は、改良のため予告なく改訂・変更する場合があります。
Materials and specifications are subject to change without manufacturer's obligation.

Precision Gear Pumps for Chemical Fiber

**SPINNING
SPIN-FINISH
VACUUM DISCHARGE
POLYCONDENSATION**

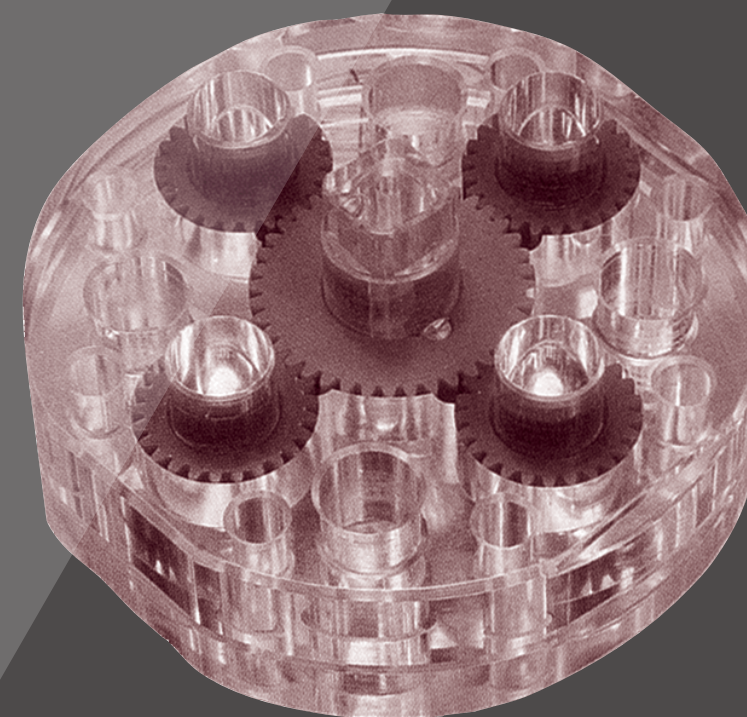





SAFETY PRECAUTIONS





Before you use the product, you **MUST** read the operation or operators manual and **MUST** fully understand how to use the product.

To use the product safely, you **MUST** carefully read all Warnings and Cautions in this manual. You **MUST** also observe the related regulations and rules regarding safety.







■Cautions related to operation

- ①  Use the safety equipment to avoid the injury when you operate the product.
- ②  Pay enough attention on handling method to avoid pinching hands or back problems that may be caused by heavy weight of the product or handling posture.
- ③  Do not step on the product, hit it, drop it or give strong outside force to it, as one of these actions may cause the failure of work, damage or oil leakage.
- ④  Wipe the oil on the product or floor off completely, as the oil creates slippery conditions that may result in dropping the product or injuring.





■Warnings and Cautions related to installation and removal of the product

- ①  Installation, removal, plumbing, and wiring must be done by the certified person.
*CERTIFIED PERSON : a person who has enough knowledge like a person who is trained by Kawasaki's hydraulic school.
- ②  Make it sure that the power of the hydraulic power unit is turned off and that the electric motor or engine has completely stopped before starting installation or removal. You must also check the system pressure has dropped to zero.
- ③  Turn off the power before starting wiring or other works related to the electric power, otherwise you may be stuck by an electric shock.
- ④  Clean the threads and mounting surface completely, otherwise you may experience damages or oil leakage caused by insufficient tightening torque or broken seal.
- ⑤  Use the specified bolts and keep the specified tightening torque when you install the product. Usage of unauthorized bolts, lack of torque or excess of torque may create problems such as failure of work, damage and oil leakage.

■Warnings and Cautions for operation

- ①  Never use the product not equipped with anti-explosion protection in the circumstances of possible explosion or combustion.
- ②  Shield the rotating part such as motor shaft and pump shaft to avoid injuries caused by being caught of fingers or cloths.
- ③  Stop the operation immediately if you find something wrong such as unusual noise, oil leakage or smoke, and fix it properly. If you continue operating, you may encounter damage, fire or injury.
- ④  Make it sure that plumbing and wiring are correct and all the connection is tightened correctly before you start operating, especially if it is the first run.
- ⑤  Use the product under the specification mentioned in the catalog, drawings and specification sheet.
- ⑥  Keep your body off the product during the operations as it may become hot and burn your body.
- ⑦  Use the proper hydraulic oil, and maintain the contamination in the recommended level, otherwise it may not work or be damaged.

■Cautions related to maintenance

- ①  Never modify the product without approval of Kawasaki.
- ②  Do not disassemble and assemble without approval by Kawasaki. It may cause troubles and failure, or it may not work as specified. If it is necessary by all means to disassemble and assemble, it must be done by an authorized person.
- ③  Keep the product from dust and rust by paying attention to the surrounding temperature and humidity when you transport or store the product.
- ④  Replacing the seals may be required if you use the product after long time storage.

PRECISION GEAR PUMP FOR CHEMICAL FIBER

OUTLINE

Kawasaki Heavy Industries has been manufacturing precision gear pumps since 1946, and their performances are unrivaled and highly acclaimed worldwide. The Kawasaki Precision Gear Pumps are produced with the highest degree of manufacturing accuracy to enhance performances of the external-contact type gear pumps, which in principle have small pulsations and good volumetric characteristics. They have been introduced in the production of chemical fibers; Vacuum discharge, Polycondensation, Spinning, Spin-finish.

FEATURES

- High accuracy of discharge volume
- Long durability
- Abundance of type to cover variety of applications
- Wear resistance
- Corrosion resistance
- Complete interchangeability of parts

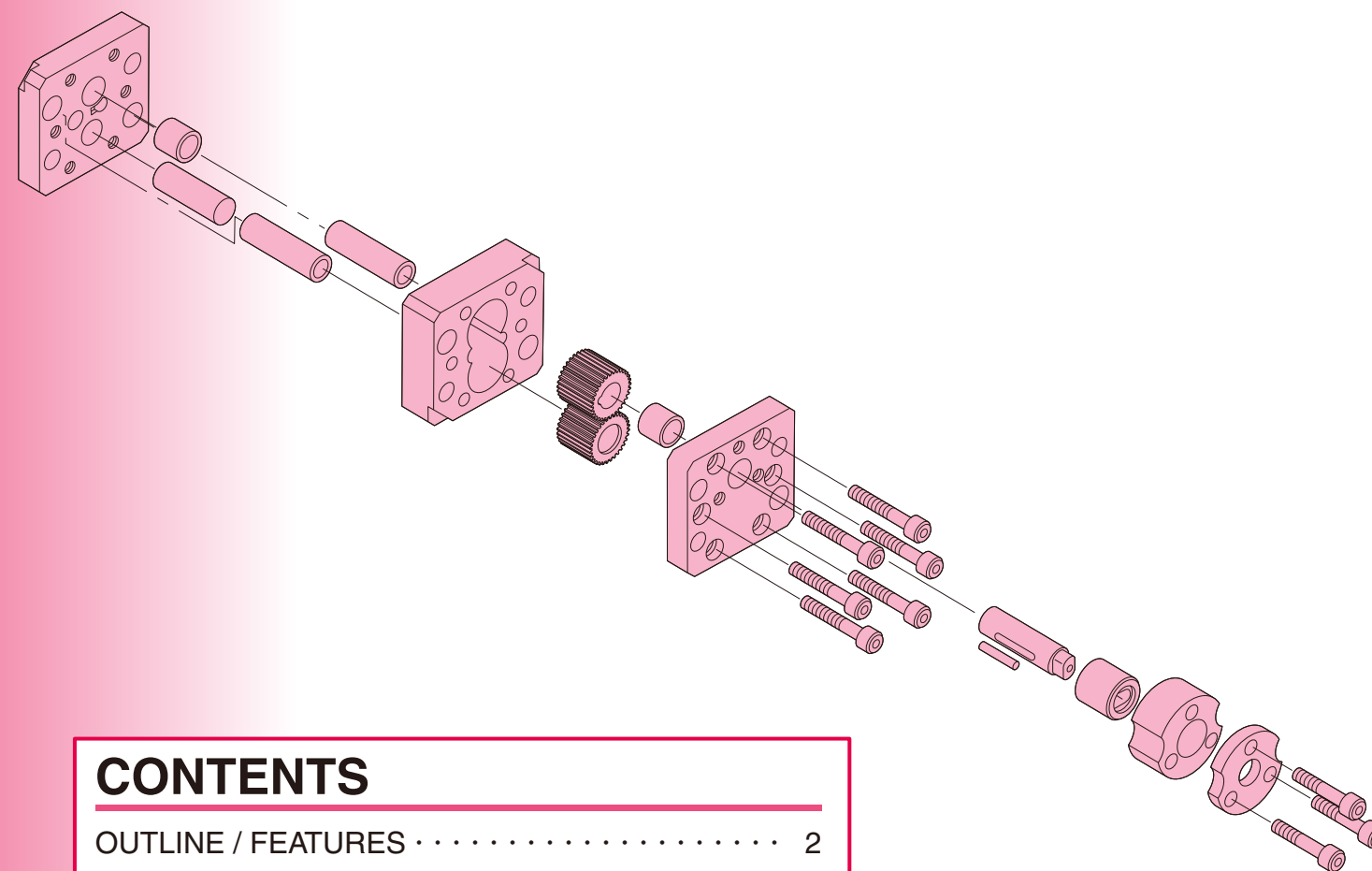

CONTENTS

OUTLINE / FEATURES	2
SPECIFICATIONS AND SELECTION	3
TORQUE TABLE	7
PUMP SERIES	8
CAUTIONS FOR HANDLING (Do and Don't)	55
INQUIRY SPECIFICATION	57

SPECIFICATION AND SELECTION

Series	Types Available for						Displacement Per Port cm ³	No. of In - Out Port	Applicable Range					
	S M	S H	S W	S F	M V	M C			Max. Outlet Pressure MPa (kgf/cm ²)	Max. Differential Pressure MPa (kgf/cm ²)	Max. Speed min ⁻¹	Max. Temperature °C	Max. Viscosity Pa · s (Poise)	
KHP-1H	X						0.1 ~ 6	1-1	49.1 (500)	39.2 (400)	40	350	400 (4,000)	
KHP-1DH	X						0.15 ~ 2.4	1-2						
KH1D-H	X						1.2 ~ 5	1-2	98.1 (1,000)	78.4 (800)	40	350	400 (4,000)	
KH7		X					0.6 ~ 3	1-1						
KH7D		X					0.6 ~ 3	1-2						
KH3	X						0.3 ~ 3	2-2	39.2 (400)	29.4 (300)	40	350	400 (4,000)	
KHP-3D	X						0.15 ~ 3	2-4						
KH3D	X						0.3 ~ 3	2-4						
KRT	X						0.6 ~ 5	2-4	49.1 (500)	39.2 (400)	40	350	400 (4,000)	
KMTD	X						0.6 ~ 1.2	2-4	39.2 (400)	29.4 (300)				
BGTD	X						0.6 ~ 2.4	2-4	49.1 (500)	39.2 (400)	40	350	400 (4,000)	
SASS	X						0.15 ~ 4.8	1-3						
SADS	X						0.15 ~ 4.8	1-6						
KH9S	X						0.1 ~ 4.8	1-4	49.1 (500)	39.2 (400)	40	350	400 (4,000)	
KH9D	X						0.1 ~ 3	1-8						
KH15S	X						3 ~ 6	1-3	19.6 (200)	19.6 (200)	40	350	400 (4,000)	
KH15D	X						3 ~ 6	1-6						
KH13S	X						0.3 ~ 6	1-6	49.1 (500)	39.2 (400)	40	350	400 (4,000)	
KH13D	X	X					0.3 ~ 2	1-12						
KH17S	X						0.8 ~ 3	1-8	49.1 (500)	39.2 (400)	40	350	400 (4,000)	
SBSS	X						4 ~ 7	1-4						
KH11D	X						5 ~ 15	2-4	19.6 (200)	19.6 (200)	40	350	400 (4,000)	
BAS	X						5 ~ 30	1-1						
BAS-H	X						5 ~ 30	1-1	49.1 (500)	39.2 (400)	40	350	400 (4,000)	
KH2-H	X						3 ~ 40	1-1						
KH2D-H	X						3 ~ 20	1-2	19.6 (200)	14.7 (150)	40	350	400 (4,000)	
IAS	X						5 ~ 20	1-1						
KH5	X						30 ~ 60	1-1	49.1 (500)	34.3 (350)	40	350	400 (4,000)	
KPS	X						30 ~ 100	1-1	19.6 (200)	14.7 (150)				
KES	X						80 ~ 200	1-1	117.7 (1,200)	98.1 (1,000)	30	350	400 (4,000)	
KH8		X					5 ~ 20	1-1	58.9 (600)	49.2 (500)	40			
SCT	X						10 ~ 50	2-2	7.8 (80)	6.9 (70)	40	350	400 (4,000)	
KAP-1			X				0.06 ~ 2.92	1-1						
KVP-1			X				0.297 ~ 2.92	1-1	7.8 (80)	6.9 (70)	40	350	400 (4,000)	
KA1D			X				0.297 ~ 1.168	1-2						
KA3			X				3 ~ 7.6	1-1	2.9 (30)	2 (20)	40	350	400 (4,000)	
KA4			X				15 ~ 30	1-1						
KV4			X				2 ~ 30	1-1	7.8 (80)	4.9 (50)	40	350	400 (4,000)	
KV5			X				60 ~ 100	1-1						
KV6			X				15 ~ 40	1-1	2.9 (30)	2 (20)	40	350	400 (4,000)	
KAP-2			X				11.1 ~ 50	1-1						
KVP-2			X				11.5 ~ 50	1-1	0.05 (0.5)	0.02 (0.2)	40	350	400 (4,000)	
KWTD				X			0.02 ~ 0.3	1-4						
KWT1D				X			0.02 ~ 0.3	1-6	0.05 (0.5)	0.02 (0.2)	40	350	400 (4,000)	
KWT2D				X			0.02 ~ 0.3	1-8						
KWT3D				X			0.02 ~ 0.3	1-12	0.05 (0.5)	0.02 (0.2)	40	350	400 (4,000)	
KWT4D				X			0.02 ~ 0.3	1-16						
KXT2D				X			0.01	1-8	49.1 (500)	39.2 (400)	40	350	400 (4,000)	
KXT3D				X			0.01	1-12						
KXT4D				X			0.01	1-16	6.9 (70)	4.9 (50)	40	350	400 (4,000)	
ZBD	X						3 ~ 10	2-2						
GDR					X		10 ~ 20	1-1	9.8 (100)	7.8 (80)	40	350	400 (4,000)	
KFS					X		30 ~ 100	1-1						
PFS					X		50 ~ 150	1-1	29.4 (300)	29.4 (300)	40	350	400 (4,000)	
HB	X						200 ~ 1,500	1-1						
HT					X		10 ~ 5,000	1-1	4.9 (50)	4.9 (50)	40	120	200 (2,000)	
B					X		300 ~ 40,000	1-1						

Series	Construction No. of Gear	Mounting Method	Material				Page
			S S	T S	H S	A	
KHP-1H	2 × 1	B			X	8	
KHP-1DH	2 × 2	B			X	9	
KH1D-H	2 × 2	B			X	9	
KH7	2 × 1	B			X	10	
KH7D	2 × 2	B			X	10	
KH3	3 × 1	B			X	11	
KHP-3D	3 × 2	B			X	12	
KH3D	3 × 2	B			X	12	
KRT	3 × 2	B			X	13	
KMTD	3 × 2	B			X	14	
BGTD	3 × 2	B			X	15	
SASS	4 × 1	B			X	16	
SADS	4 × 2	B			X	17	
KH9S	5 × 1	B			X	18	
KH9D	5 × 2	B			X	19	
KH15S	4 × 1	B			X	20	
KH15D	4 × 2	B			X	20	
KH13S	7 × 1	B			X	21	
KH13D	7 × 2	B			X	22	
KH17S	9 × 1	B			X	23	
SBSS	5 × 1	B			X	24	
KH11D	3 × 2	B			X	25	
BAS	2 × 1	B		X		26	
BAS-H	2 × 1	B		X		27	
KH2-H	2 × 1	B			X	28	
KH2D-H	2 × 2	B			X	29	
IAS	2 × 1	B			X	30	
KH5	2 × 1	B		X		31	
KPS	2 × 1	B		X		32	
KES	2 × 1	B		X		33	
KH8	2 × 1	B			X	34	
SCT	3 × 1	B			X	35	
KAP-1	2 × 1	S	X			36	
KVP-1	2 × 1	S	X			37	
KA1D	2 × 2	S	X			38	
KA3	2 × 1	S	X			39	
KA4	2 × 1	S	X			40	
KV4	2 × 1	S	X			41	
KV5	2 × 1	S	X			41	
KV6	2 × 1	S	X			41	
KAP-2	3 × 1	S	X			43	
KVP-2	3 × 1	S	X			44	
KWTD	3 × 2	F	X			45	
KWT1D	3 × 3	F	X			45	
KWT2D	3 × 4	F	X			45	
KWT3D	3 × 6	F	X			45	
KWT4D	3 × 8	F	X			45	
KXT2D	3 × 4	F	X			47	
KXT3D	3 × 6	F	X			47	
KXT4D	3 × 8	F	X			47	
ZBD	2 × 2	B			X	48	
GDR	2 × 1	B			X	49	
KFS	2 × 1	B			X	50	
PFS	2 × 1	B			X	51	
HB	2 × 1	B		X		52	
HT	2 × 1	T.F		X		53	
B	2 × 1	F	X			54	

1. Types Available for:

- SM Melt spinning / pelletizing
- SH Melt spinning, high pressure version
- SW Wet & dry spinning
- SF Spin-finish application
- MV Miscellaneous, vacuum discharge
- MC Miscellaneous, corrosive liquid

2. No. of Gear:

Number of metering gear per stack × number of stack

3. Mounting Method: See Table 1 (page 5)

- B Block mounting
- S Saddle mounting
- F Foot mounting
- T Tank mounting

4. Material of Main Parts:

- SS Stainless steel
- TS Alloy tool steel
- HS High speed tool steel
- SA Special corrosion-wear-resistant material

5. Features of Shaft Seal: See Table 2 (page 6)

Table 1. Mounting method

•Block mounting

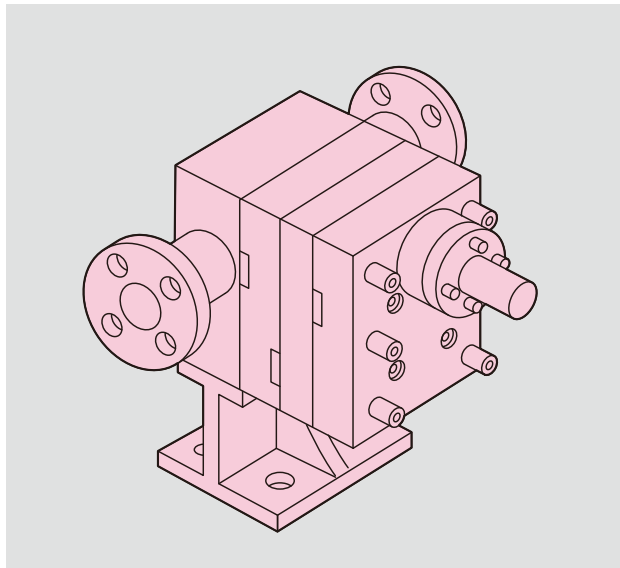

These pumps are mounted on a special block, to which piping is connected.

•Saddle mounting

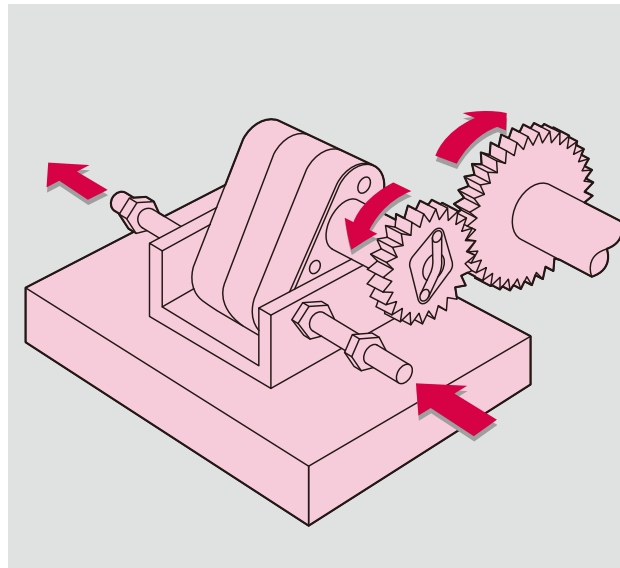

These pumps are fastened by pushing the trunnions screwed in the saddle to the pump's inlet and outlet. The pumps can be tilted around its axis passing the inlet and outlet for quick on-off engagement.

•Tank mounting

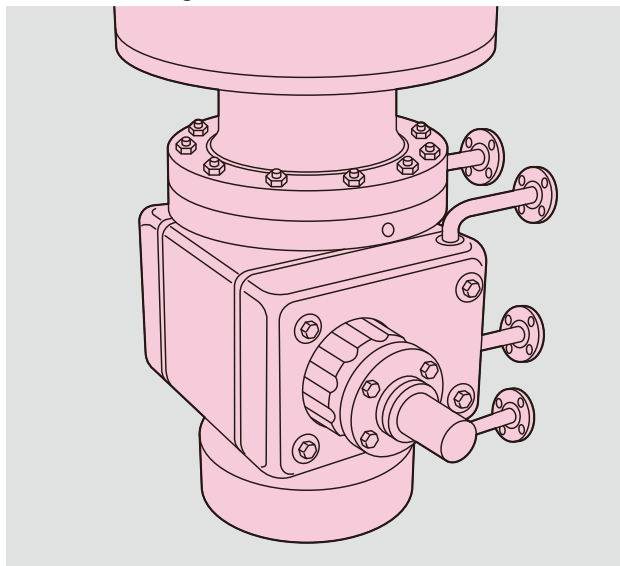

These pumps are directly mounted on a tank bottom.

•Foot mounting

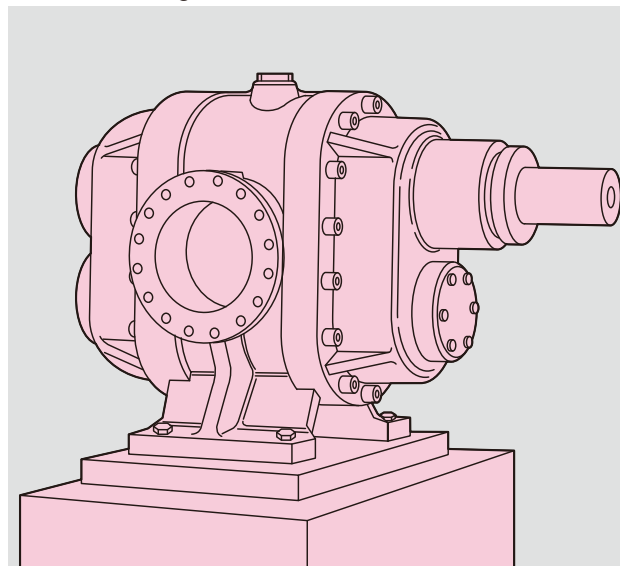

These pumps are installed on a common bed.

Table 2. Features of shaft-seal

Features of shaft-seals are as follows. Such special seals as teflon lip seal, etc. are also available.

•Sealing coupler

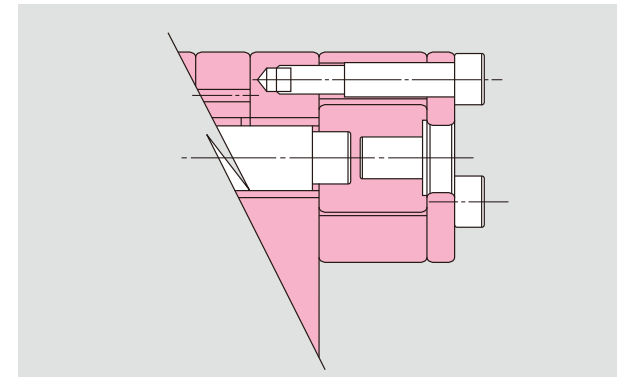

The coupler functions as both coupling and seals. It is especially appropriate for high viscosities.

•Gland packing

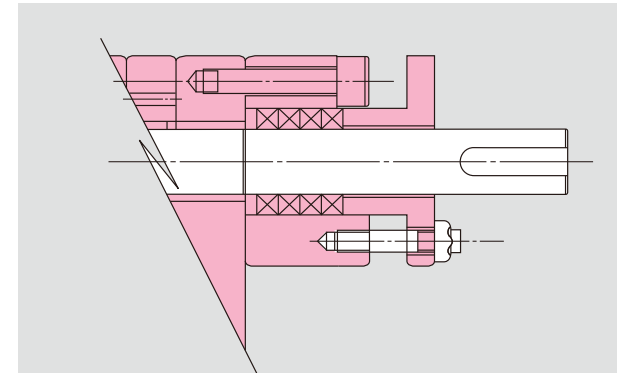

Teflon is standard packing material. (Carbon-fiber is used for high temperature applications.) This is simple and easy to care.

•Metal seal + Gland packing

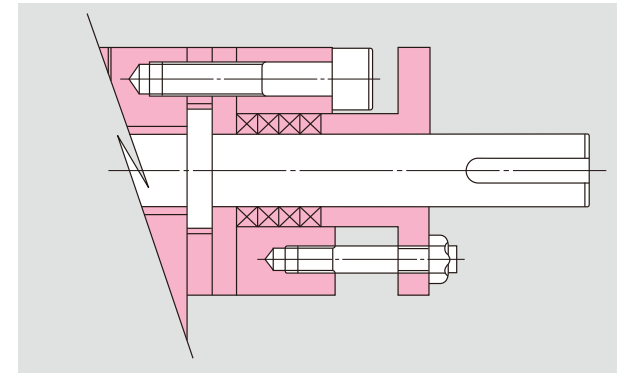

This is a double seal and thrust force is supported by the seal ring. This is suitable for a pump of small capacity under high pressure use.

•Metal seal

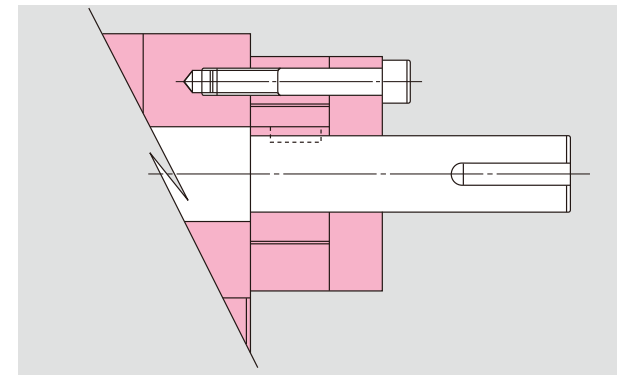

•Special mechanical seal

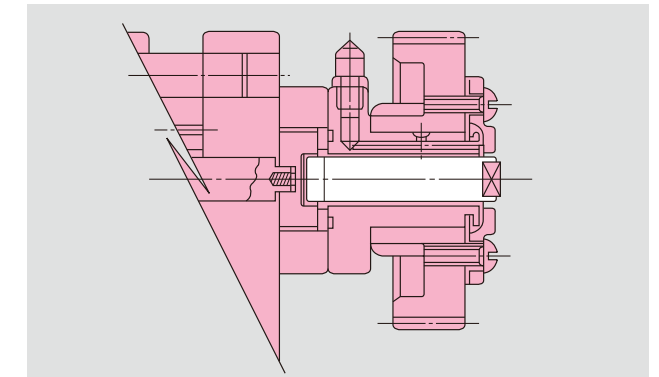

This seal has been specially designed for outer-gear drive pumps. It is compact and suitable for low viscosity liquids.

•Ring seal

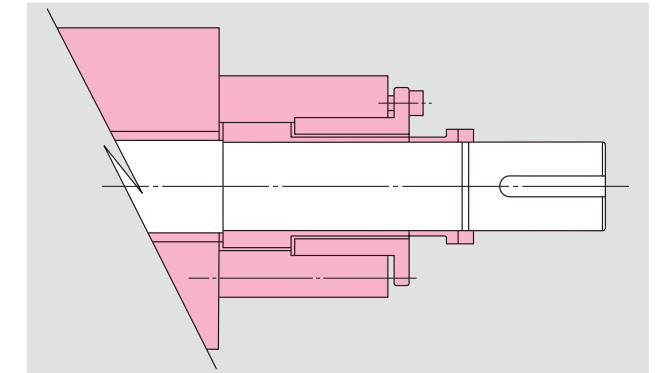

Long durability is ensured since there are no frictional parts. Leakage can be controlled by adjusting the clearance "t".

•Mechanical seal

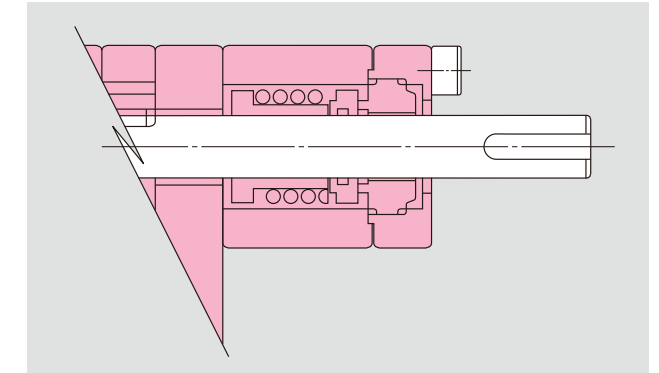

Standard combination of material is special alloy and teflon. This seal is suitable for corrosive liquids but can not be used above 200°C.

Sealing function is performed when the seal-ring, installed on the driving shaft, is pushed against the hub top. This is used when viscosity is high and a gland packing is not appropriate.

TORQUE TABLE

KAWASAKI PRECISION GEAR PUMPS are so designed that bolts are to be tightened with the torque listed below. Under-torque will cause leakage of liquid both inside of the pump and out of the pump. Over-torque may cause a look of the metering gears.

BOLT SIZE	ALLOY STEEL		STAINLESS STEEL	
	N·m	kgf·cm	N·m	kgf·cm
#10-24UNC	4.4~4.9	45~50	2.2~2.5	22~25
#12-24UNC	6.9~7.8	70~80	3.4~3.9	35~40
1/4"-20UNC	9.8~11.8	100~120	4.9~5.9	50~60
5/16"-18UNC	21.6~24.5	220~250	10.8~12.3	110~125
3/8"-16UNC	44.1~49.1	450~500	22.1~24.5	225~250
1/2"-13UNC	107.9~117.7	1,100~1,200	54~58.9	550~600
M 5	4.9~5.9	50~60	2.5~2.9	25~30
M 6	9.8~11.8	100~120	4.9~5.9	50~60
M 8	24.5~27.5	250~280	12.3~13.7	125~140
M 10	49.1~53.9	500~550	24.5~27	250~275
M 12	88.3~94.2	900~960	44.1~47.1	450~480
M 14	137.3~147.2	1,400~1,500	68.7~73.6	700~750
M 16	225.6~245.3	2,300~2,500	112.8~122.6	1,150~1,250
M 18	264.9~294.3	2,700~3,000	132.4~147.2	1,350~1,500
M 20	382.6~412	3,900~4,200	191.3~206	1,950~2,100
M 22	529.7~539.6	5,400~5,500	—	—
M 24	676.9~686.7	6,900~7,000	—	—
M 27	981.0~990.8	10,000~10,100	—	—
M 30	1,275.3~1,285.1	13,000~13,100	—	—

CAUTION: 1. Apply DAG DISPERSION #580 or #654 or other suitable lubricant on the thread before tightening the bolts with a torque wrench.
2. Tighten the bolts at the operation temperature.

KHP-1H SERIES

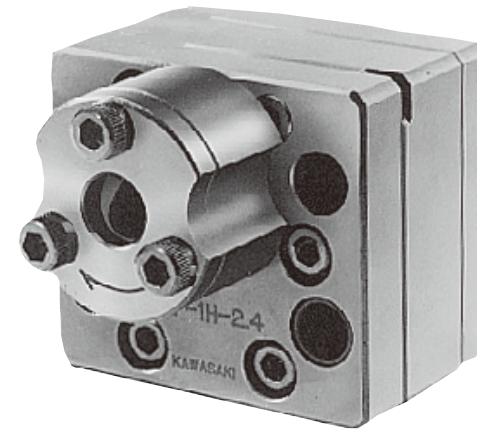

Main application : Melt spinning
 Number of ports : Inlet 1 ; Outlet 1
 Displacement / port : 0.1 ~ 6 cm³
 Inlet pressure : 0.5 MPa~19.6 MPa (5 kgf/cm² ~200 kgf/cm²)
 Outlet pressure : Max. 49.1 MPa (Max. 500 kgf/cm²)
 Differential pressure : Please refer to table as shown below.
 Temperature : Max. 350 °C
 Viscosity : Max. 400 Pa·s (Max. 4,000 Poise)
 Speed : 10 ~ 40 min⁻¹
 Standard material : High speed tool steel
 Torque list :

	Bolt size	Torque	
		N·m	kgf·cm
For plates	M6	9.8~11.8	100~120
For hub	M6	9.8~11.8	100~120
For mounting	M10	49.1~53.9	500~550

STRUCTURE DIMENSIONS (mm)

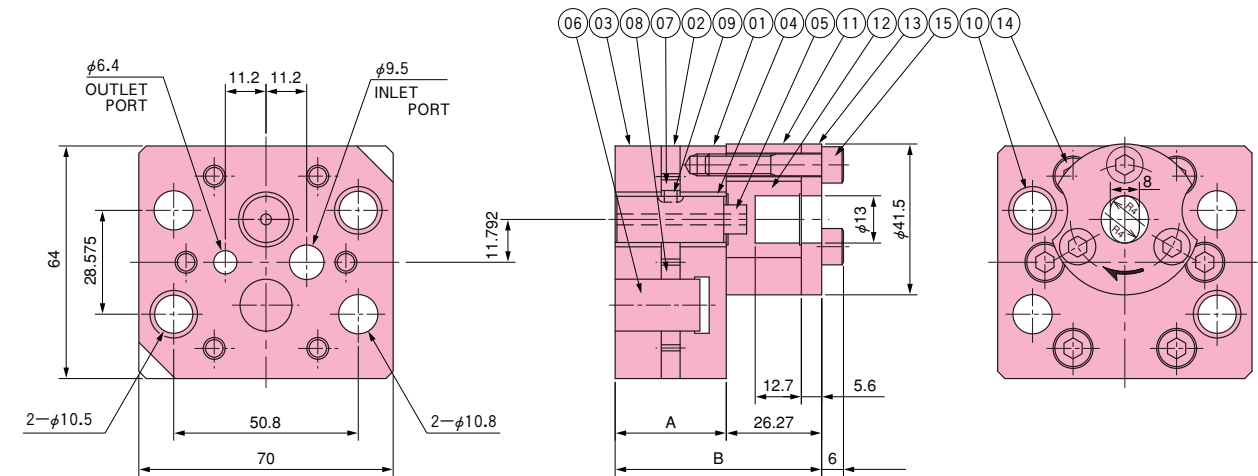

Model	Capacity (cm ³)	Diff. Press.		A	B	Mass (kg)
		MPa	kgf/cm ²			
KHP-1H-0.1	0.1	39.2	400	27.01	53.28	1.2
KHP-1H-0.15	0.15	39.2	400	27.28	53.55	1.2
KHP-1H-0.3	0.3	39.2	400	29.15	55.42	1.3
KHP-1H-0.6	0.6	39.2	400	30.58	56.85	1.4
KHP-1H-1.2	1.2	39.2	400	35.76	62.03	1.6
KHP-1H-1.6	1.6	39.2	400	39.21	65.48	1.7
KHP-1H-1.8	1.8	39.2	400	40.93	67.2	1.8
KHP-1H-2.4	2.4	39.2	400	46.12	72.39	1.9
KHP-1H-3	3.0	29.4	300	42.5	68.77	1.8
KHP-1H-4	4.0	29.4	300	48.2	74.47	2
KHP-1H-5	5.0	24.5	250	54	80.27	2.2
KHP-1H-6	6.0	24.5	250	59.7	85.97	2.4

Parts List

Parts No.	Name	Q'ty/set
01	Front plate	1
02	Gear casing	1
03	Back plate	1
04	Bushing	2
05	Arbor	1
06	Stud	1
07	Driving gear	1
08	Driven gear	1
09	Key	1
10	Dowel	2
11	Hub	1
12	Coupler	1
13	Hub top	1
14	Plate screw	6
15	Hub screw	3

KHP-1DH/KH1D-H SERIES

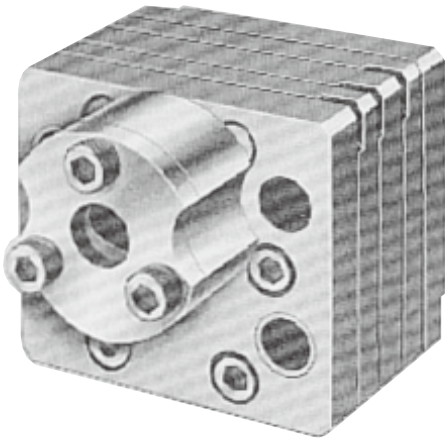

Main application : Melt spinning
 Number of ports : Inlet 1 ; Outlet 2
 Displacement / port : 0.15 ~ 5 cm³
 Inlet pressure : 0.5 MPa~19.6 MPa (5 kgf/cm² ~ 200 kgf/cm²)
 Outlet pressure : Max. 49.1 MPa (Max. 500 kgf/cm²)
 Differential pressure : Please refer to table as shown below.
 Temperature : Max. 350 °C
 Viscosity : Max. 400 Pa·s (Max. 4,000 Poise)
 Speed : 10 ~ 40 min⁻¹
 Standard material : High speed tool steel

Torque list :

	Bolt size	Torque	
		N·m	kgf·cm
For plates	M6	9.8~11.8	100~120
For hub	M5	4.9~ 5.9	50~ 60
For mounting	M10	49.1~53.9	500~550

STRUCTURE DIMENSIONS (mm)

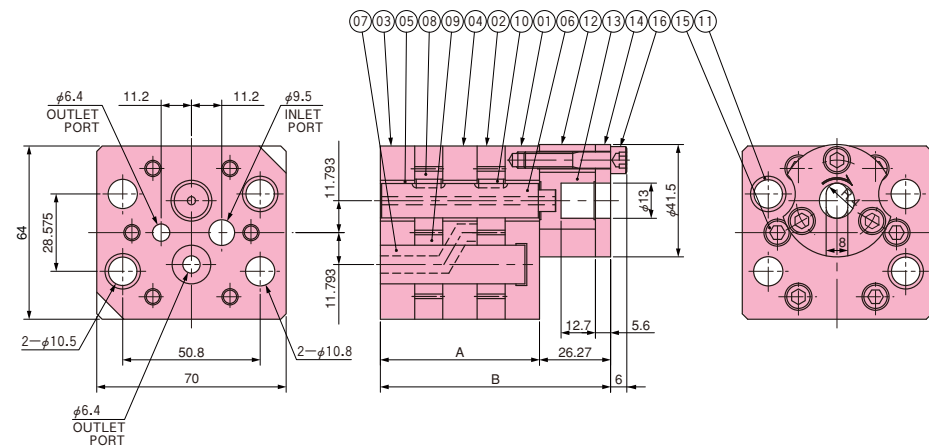

Parts List

Parts No.	Name	Q'ty/set
01	Front plate	1
02	Gear casing	2
03	Back plate	1
04	Middle plate	1
05	Bushing	3
06	Arbor	1
07	Stud	1
08	Driving gear	2
09	Driven gear	2
10	Key	2
11	Dowel	2
12	Hub	1
13	Coupler	1
14	Hub top	1
15	Plate screw	6
16	Hub screw	3

Model	Capacity (cm ³)	Diff. Press. MPa	kgf/cm ²	A	B	Mass (kg)	Model	Capacity (cm ³)	Diff. Press. MPa	kgf/cm ²	A	B	Mass (kg)
KHP-1DH-0.15	0.15×2	39.2	400	41.9	68.17	1.6	KHP-1DH-1.2	1.2×2	39.2	400	58.8	85.07	2.2
KHP-1DH-0.3	0.3×2	39.2	400	45.6	71.87	1.6	KHP-1DH-1.6	1.6×2	39.2	450	65.7	91.97	2.5
KHP-1DH-0.6	0.6×2	39.2	400	48.5	74.77	1.8	KHP-1DH-2.4	2.4×2	24.5	250	65.3	91.57	2.4

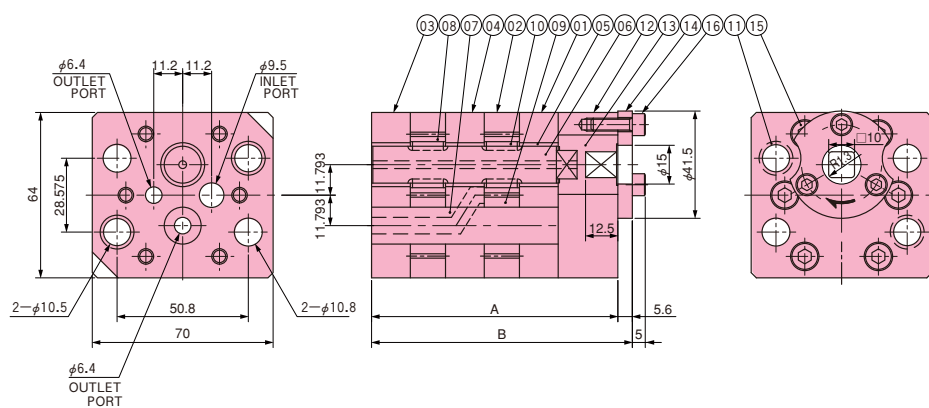

Parts List

Parts No.	Name	Q'ty/set
01	Front plate	1
02	Gear casing	2
03	Back plate	1
04	Middle plate	1
05	Bushing	3
06	Arbor	1
07	Stud	1
08	Driving gear	2
09	Driven gear	2
10	Key	4
11	Dowel	2
12	Hub	1
13	Coupler	1
14	Hub top	1
15	Plate screw	6
16	Hub screw	3

Model	Capacity (cm ³)	Diff. Press. MPa	kgf/cm ²	A	B	Mass (kg)	Model	Capacity (cm ³)	Diff. Press. MPa	kgf/cm ²	A	B	Mass (kg)
KH1D-1.2-H	1.2×2	39.2	400	81.9	87.5	2.9	KH1D-3-H	3×2	39.2	400	106.3	114.3	3.8
KH1D-1.6-H	1.6×2	39.2	400	88.8	94.4	3.2	KH1D-4-H	4×2	29.4	300	113.7	121.7	4.1
KH1D-2.4-H	2.4×2	39.2	400	99.3	104.9	3.6	KH1D-5-H	5×2	29.4	300	125.3	133.3	4.5

KH7/KH7D SERIES

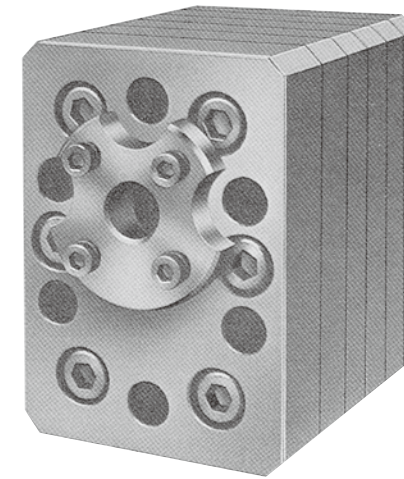

Main application : Melt spinning
 Number of ports : Inlet 1 ; Outlet 1 (KH7), 2 (KH7D)
 Displacement / port : 0.6 ~ 3 cm³
 Inlet pressure : 0.5 MPa~19.6 MPa (5 kgf/cm² ~ 200 kgf/cm²)
 Outlet pressure : Max. 98.1 MPa (Max. 1,000 kgf/cm²)
 Differential pressure : Please refer to table as shown below.
 Temperature : Max. 350 °C
 Viscosity : Max. 400 Pa·s (Max. 4,000 Poise)
 Speed : 10 ~ 40 min⁻¹
 Standard material : High speed tool steel

Torque list :

	Bolt size	Torque	
		N·m	kgf·cm
For plates	M10	49.1~53.4	500~550
For hub	M6	9.8~11.8	100~120
For mounting	M12	88.3~94.2	900~960

STRUCTURE DIMENSIONS (mm)

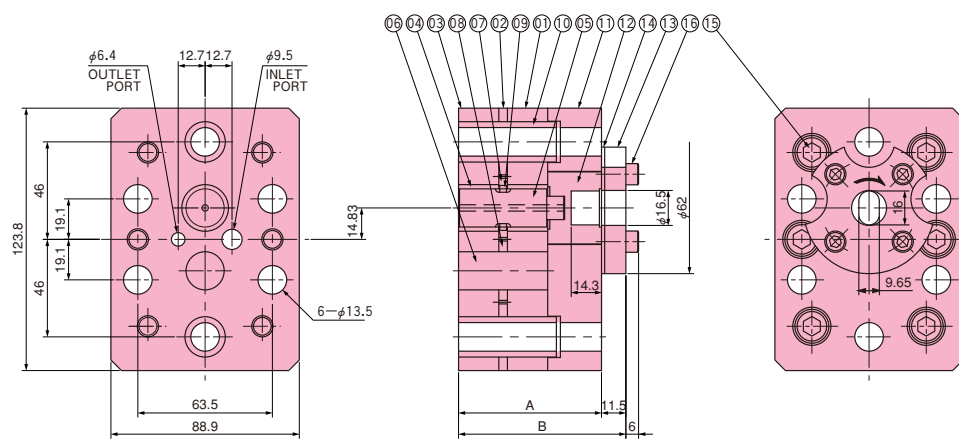

Parts List

Parts No.	Name	Q'ty/set
01	Front plate	1
02	Gear casing	1
03	Back plate	1
04	Bushing	2
05	Arbor	1
06	Stud	1
07	Driving gear	1
08	Driven gear	1
09	Key	2
10	Dowel	2
11	Hub	1
12	Coupler	1
13	Hub top	1
14	Seal plate	1
15	Plate screw	6
16	Hub screw	4

Model	Capacity (cm ³)	Diff. Press. MPa	kgf/cm ²	A	B	Mass (kg)	Model	Capacity (cm ³)	Diff. Press. MPa	kgf/cm ²	A	B	Mass (kg)
KH7-0.6	0.6	78.5	800	67.5	77.5	5.9	KH7-2.4	2.4	78.5	800	79.8	89.8	7
KH7-1.2	1.2	78.5	800	71.6	81.6	6.3	KH7-3.0	3.0	78.5	800	84	94	7.3
KH7-1.6	1.6	78.5	800	74.4	84.4	6.5							

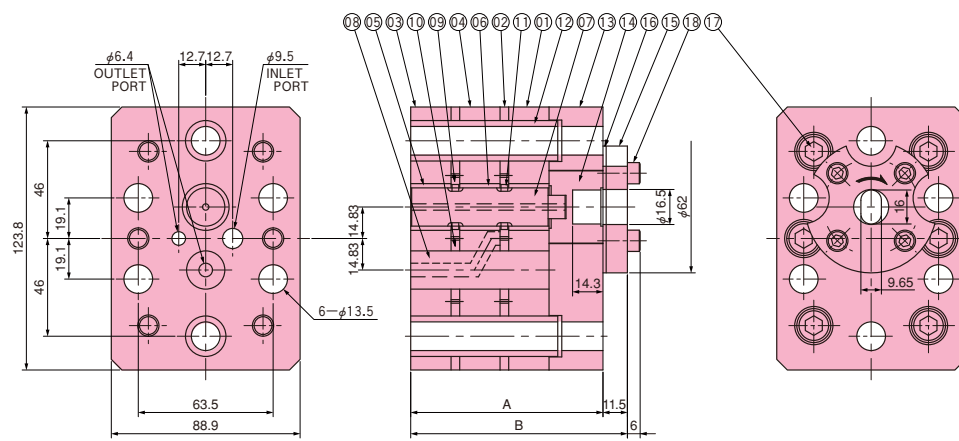

Parts List

Parts No.	Name	Q'ty/set
01	Front plate	1
02	Gear casing	2
03	Back plate	1
04	Middle plate	1
05	Bushing	2
06	Bushing	1
07	Arbor	1
08	Stud	1
09	Driving gear	2
10	Driven gear	2
11	Key	4
12	Dowel	2
13	Hub	1
14	Coupler	1
15	Hub top	1
16	Seal plate	1
17	Plate screw	6
18	Hub screw	4

Model	Capacity (cm ³)	Diff. Press. MPa	kgf/cm ²	A	B	Mass (kg)	Model	Capacity (cm ³)	Diff. Press. MPa	kgf/cm ²	A	B	Mass (kg)
KH7D-0.6	0.6×2	78.5	800	90.6	100.6	7.9	KH7D-2.4	2.4×2	49.1	500	115.3	125.3	10
KH7D-1.2	1.2×2	78.5	800	98.8	108.8	8.6	KH7D-3.0	3.0×2	39.2	400	123.5	133.5	10.8
KH7D-1.6	1.6×2	78.5	800	104.3	114.3	9.1							

KH3 SERIES

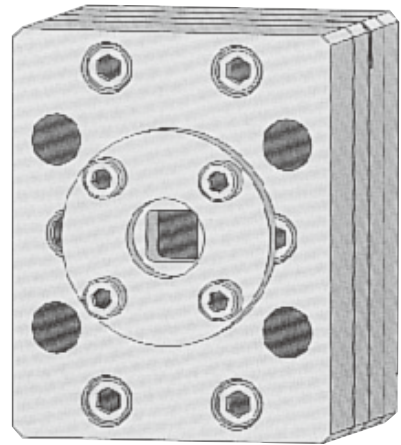

Main application : Melt spinning
 Number of ports : Inlet 2 ; Outlet 2
 Displacement / port : 0.3 ~ 3 cm³
 Inlet pressure : 0.5 MPa~19.6 MPa (5 kgf/cm² ~ 200 kgf/cm²)
 Outlet pressure : Max. 39.2 MPa (Max. 400 kgf/cm²)
 Differential pressure : Please refer to table as shown below.
 Temperature : Max. 350 °C
 Viscosity : Max. 400 Pa·s (Max. 4,000 Poise)
 Speed : 10 ~ 40 min⁻¹
 Standard material : High speed tool steel
 Torque list :

	Bolt size	Torque	
		N·m	kgf·cm
For plates	M6	9.8~11.8	100~120
For hub	M5	4.9~5.9	50~60
For mounting	M10	49.1~53.9	500~550

STRUCTURE DIMENSIONS (mm)

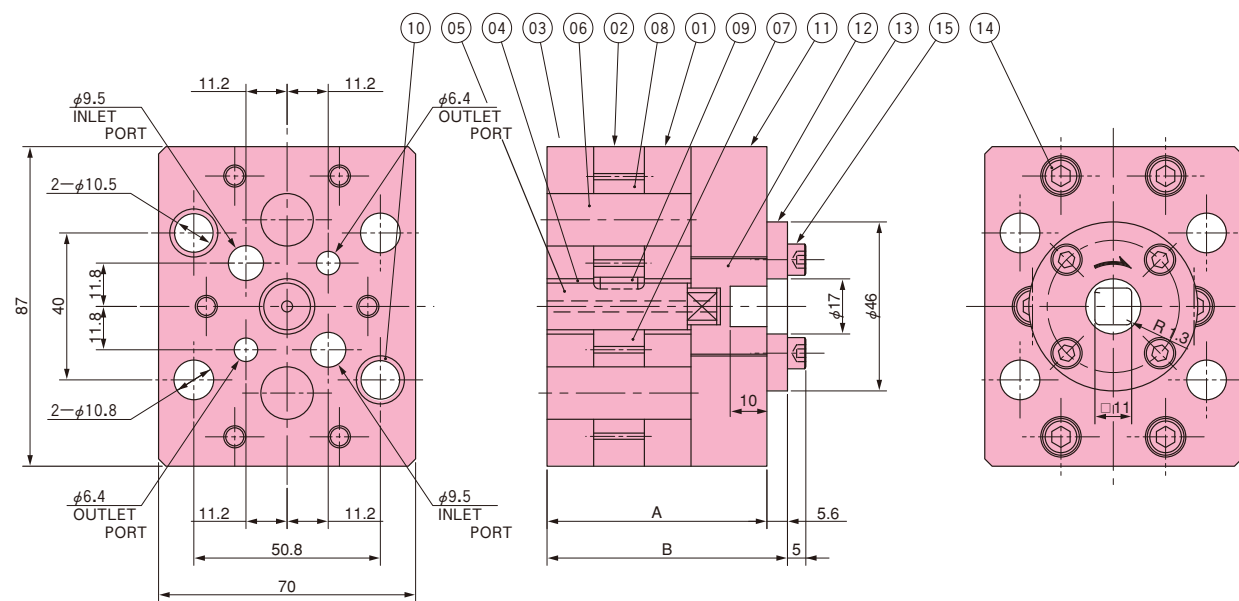

Model	Capacity (cm ³)	Diff. Press.		A	B	Mass (kg)
		MPa	kgf/cm ²			
KH3-0.3	0.3×2	29.4	300	49.8	55.4	2.4
KH3-0.6	0.6×2	29.4	300	51.2	56.8	2.5
KH3-1.2	1.2×2	29.4	300	56.4	62	2.7
KH3-2.4	2.4×2	29.4	300	59.7	65.3	2.9
KH3-3	3.0×2	29.4	300	63.2	68.8	3.1

Parts List

Parts No.	Name	Q'ty/set
01	Front plate	1
02	Gear casing	1
03	Back plate	1
04	Bushing	2
05	Arbor	1
06	Stud	2
07	Driving gear	1
08	Driven gear	2
09	Key	1
10	Dowel	2
11	Hub	1
12	Coupler	1
13	Hub top	1
14	Plate screw	6
15	Hub screw	4

KHP-3D/KH3D SERIES

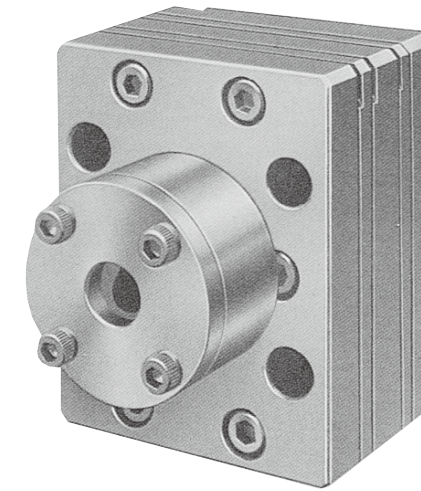

Main application : Melt spinning
 Number of ports : Inlet 2 ; Outlet 4
 Displacement / port : 0.15 ~ 3 cm³
 Inlet pressure : 0.5 MPa~19.6 MPa (5 kgf/cm² ~ 200 kgf/cm²)
 Outlet pressure : Max. 39.2 MPa (Max. 400 kgf/cm²)
 Differential pressure : Please refer to table as shown below.
 Temperature : Max. 350 °C
 Viscosity : Max. 400 Pa·s (Max. 4,000 Poise)
 Speed : 10 ~ 40 min⁻¹
 Standard material : High speed tool steel
 Torque list :

	Bolt size	Torque	
		N·m	kgf·cm
For plates	M6	9.8~11.8	100~120
For hub	M5	4.9~5.9	50~60
For mounting	M10	49.1~53.9	500~550

STRUCTURE DIMENSIONS (mm)

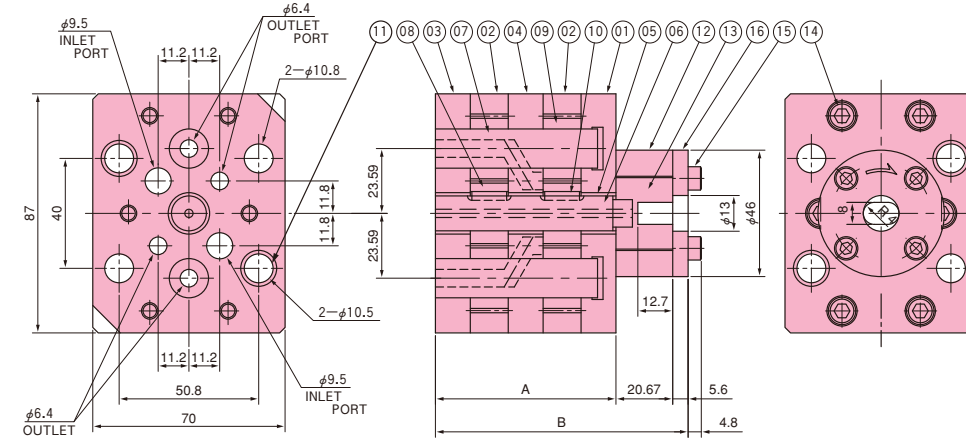

Model	Capacity (cm ³)	Diff. Press.		A	B	Mass (kg)	Model	Capacity (cm ³)	Diff. Press.		A	B	Mass (kg)
		MPa	kgf/cm ²						MPa	kgf/cm ²			
KHP-3D-0.15	0.15×4	19.6	200	41.9	68.17	2.4	KHP-3D-1.6	1.6×4	19.6	200	65.7	91.97	3.5
KHP-3D-0.3	0.3×4	19.6	200	45.6	71.87	2.6	KHP-3D-2.4	2.4×4	14.7	150	65.5	91.77	3.5
KHP-3D-0.6	0.6×4	19.6	200	48.5	74.77	2.7	KHP-3D-3.0	3.0×4	9.8	100	72.3	98.57	3.9
KHP-3D-1.2	1.2×4	19.6	200	58.8	85.07	3.2							

Parts List

Parts No.	Name	Q'ty/set
01	Front plate	1
02	Gear casing	2
03	Back plate	1
04	Middle plate	1
05	Bushing	3
06	Arbor	1
07	Stud	2
08	Driving gear	2
09	Driven gear	4
10	Key	2
11	Dowel	2
12	Hub	1
13	Coupler	1
14	Plate screw	6
15	Hub screw	4
16	Hub top	1

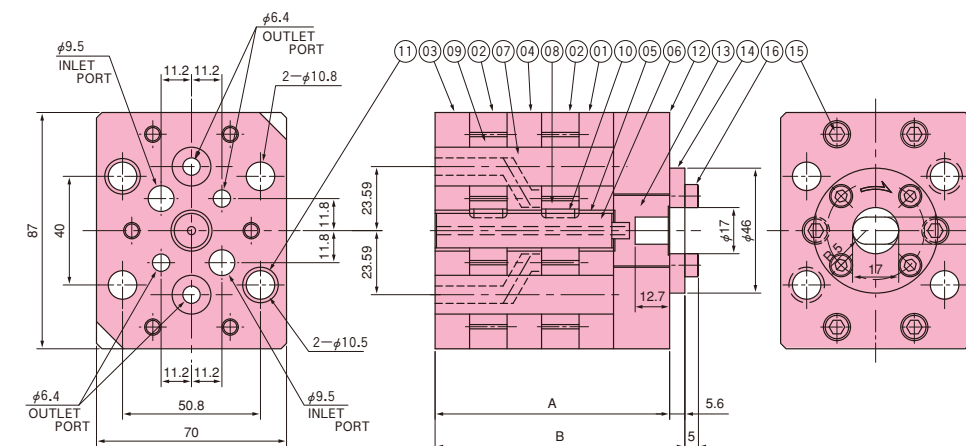

Model	Capacity (cm ³)	Diff. Press.		A	B	Mass (kg)	Model	Capacity (cm ³)	Diff. Press.		A	B	Mass (kg)
		MPa	kgf/cm ²						MPa	kgf/cm ²			
KH3D-0.3	0.3×4	29.4	300	66.2	71.8	3.2	KH3D-1.6	1.6×4	29.4	300	86.4	92	4.2
KH3D-0.6	0.6×4	29.4	300	69.1	74.7	3.4	KH3D-2.4	2.4×4	24.5	250	90.7	96.3	4.4
KH3D-1.2	1.2×4	29.4	300	79.5	85.1	3.9	KH3D-3.0	3.0×4	24.5	250	97.7	103.3	4.8

Parts List

Parts No.	Name	Q'ty/set
01	Front plate	1
02	Gear casing	2
03	Back plate	1
04	Middle plate	1
05	Bushing	3
06	Arbor	1
07	Stud	2
08	Driving gear	2
09	Driven gear	4
10	Key	2
11	Dowel	2
12	Hub	1
13	Coupler	1
14	Hub top	1
15	Plate screw	6
16	Hub screw	4

KRT SERIES

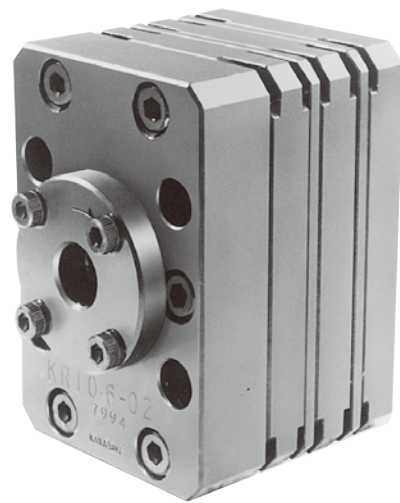

Main application : Melt spinning
 Number of ports : Inlet 2 ; Outlet 4
 Displacement / port : 0.6 ~ 5 cm³
 Inlet pressure : 0.5 MPa~19.6 MPa (5 kgf/cm² ~ 200 kgf/cm²)
 Outlet pressure : Max. 49.1 MPa (Max. 500 kgf/cm²)
 Differential pressure : Please refer to table as shown below.
 Temperature : Max. 350 °C
 Viscosity : Max. 400 Pa·s (Max. 4,000 Poise)
 Speed : 10 ~ 40 min⁻¹
 Standard material : High speed tool steel
 Torque list :

	Bolt size	Torque	
		N·m	kgf·cm
For plates	M8	24.5~27.5	250~280
For hub	M6	9.8~11.8	100~120
For mounting	M12	88.3~94.2	900~960

STRUCTURE DIMENSIONS (mm)

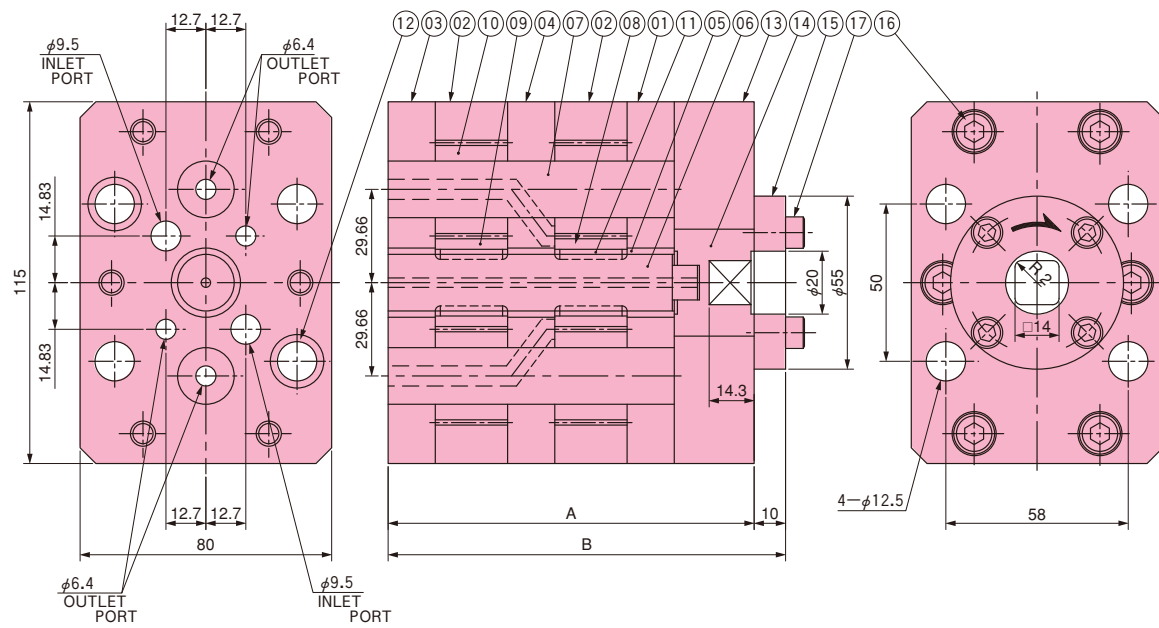

Model	Capacity (cm ³)	Diff. Press.		A	B	Mass (kg)
		MPa	kgf/cm ²			
KRT-0.6	0.6×4	39.2	400	78.5	88.5	5.8
KRT-1.2	1.2×4	39.2	400	86.7	96.7	6.4
KRT-1.6	1.6×4	39.2	400	92.2	102.2	6.8
KRT-2.4	2.4×4	39.2	400	103	113	7.6
KRT-3	3.0×4	39.2	400	111.2	121.2	8.2
KRT-4	4.0×4	29.4	300	107.1	117.1	7.9
KRT-5	5.0×4	29.4	300	116.4	126.4	8.5

Parts List

Parts No.	Name	Q'ty/set
01	Front plate	1
02	Gear casing	2
03	Back plate	1
04	Middle plate	1
05	Bushing	3
06	Arbor	1
07	Stud	1
08	Driving gear	1
09	Driving gear	1
10	Driven gear	4
11	Key	4
12	Dowel	2
13	Hub	1
14	Coupler	1
15	Hub top	1
16	Plate screw	6
17	Hub screw	4

KMTD SERIES

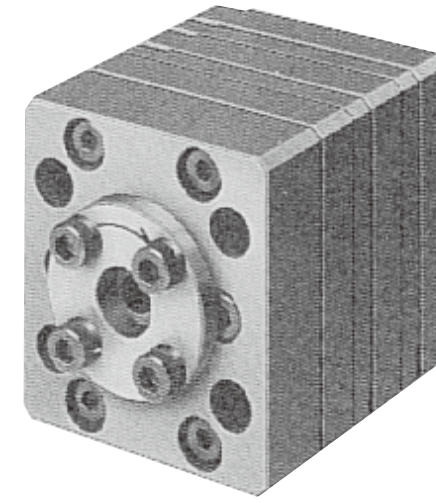

Main application : Melt spinning
 Number of ports : Inlet 2 ; Outlet 4
 Displacement / port : 0.6 ~ 1.2 cm³
 Inlet pressure : 0.5 MPa~19.6 MPa (5 kgf/cm² ~ 200 kgf/cm²)
 Outlet pressure : Max. 39.2 MPa (Max. 400 kgf/cm²)
 Differential pressure : Please refer to table as shown below.
 Temperature : Max. 350 °C
 Viscosity : Max. 400 Pa·s (Max. 4,000 Poise)
 Speed : 10 ~ 40 min⁻¹
 Standard material : High speed tool steel
 Torque list :

	Bolt size	Torque	
		N·m	kgf·cm
For plates	M6	9.8~11.8	100~120
For hub	M6	9.8~11.8	100~120
For mounting	M10	49.1~53.9	500~550

STRUCTURE DIMENSIONS (mm)

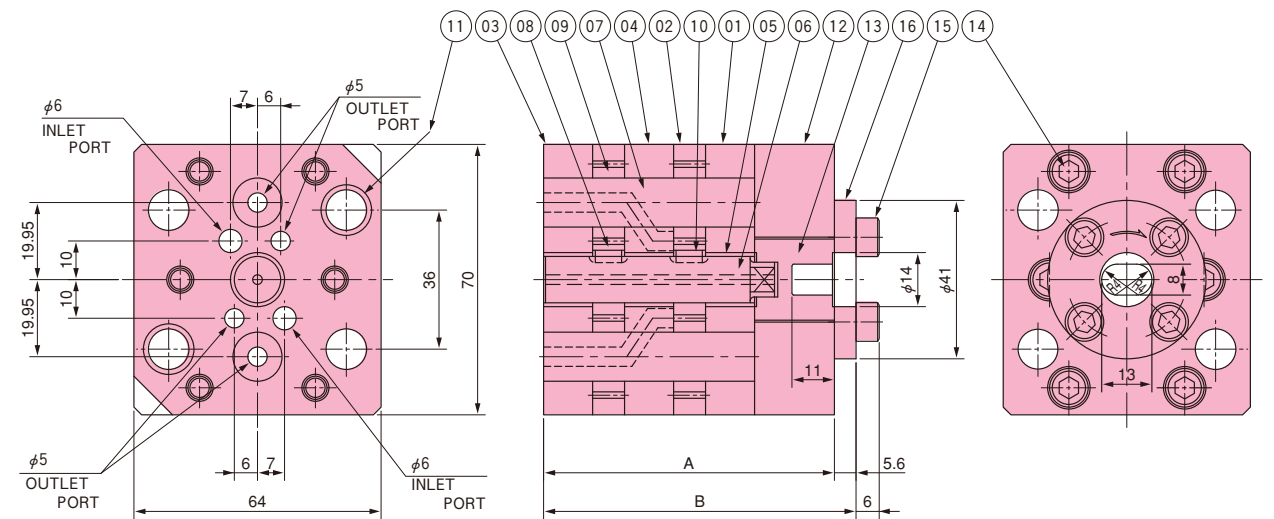

Model	Capacity (cm ³)	Diff. Press.		A	B	Mass (kg)
		MPa	kgf/cm ²			
KMTD-0.6	0.6×4	29.4	300	70	76.6	2.5
KMTD-0.7	0.7×4	29.4	300	73.2	78.8	2.6
KMTD-0.8	0.8×4	29.4	300	75.3	80.9	2.7
KMTD-1.2	1.2×4	29.4	300	83.2	88.8	3

Parts List

Parts No.	Name	Q'ty/set
01	Front plate	1
02	Gear casing	2
03	Back plate	1
04	Middle plate	1
05	Bushing	3
06	Arbor	1
07	Stud	2
08	Driving gear	2
09	Driven gear	4
10	Key	2
11	Dowel	2
12	Hub	1
13	Coupler	1
14	Plate screw	6
15	Hub screw	4
16	Hub top	1

BGTD SERIES

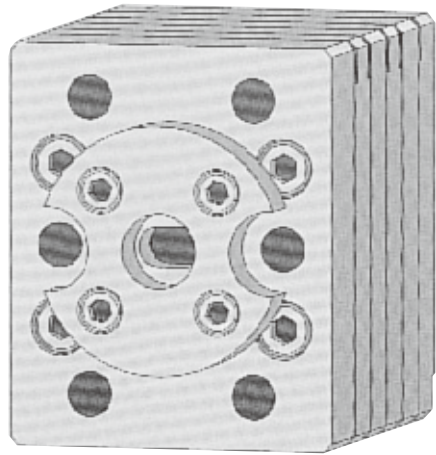

Main application : Melt spinning
 Number of ports : Inlet 2 ; Outlet 4
 Displacement / port : 0.6 ~ 2.4 cm³
 Inlet pressure : 0.5 MPa~19.6 MPa (5 kgf/cm² ~ 200 kgf/cm²)
 Outlet pressure : Max. 49.1 MPa (Max. 500 kgf/cm²)
 Differential pressure : Please refer to table as shown below.
 Temperature : Max. 350 °C
 Viscosity : Max. 400 Pa·s (Max. 4,000 Poise)
 Speed : 10 ~ 40 min⁻¹
 Standard material : High speed tool steel
 Torque list :

	Bolt size	Torque	
		N·m	kgf·cm
For plates	M8	24.5~27.5	250~280
For hub	M6	9.8~11.8	100~120
For mounting	M10	49.1~53.9	500~550

STRUCTURE DIMENSIONS (mm)

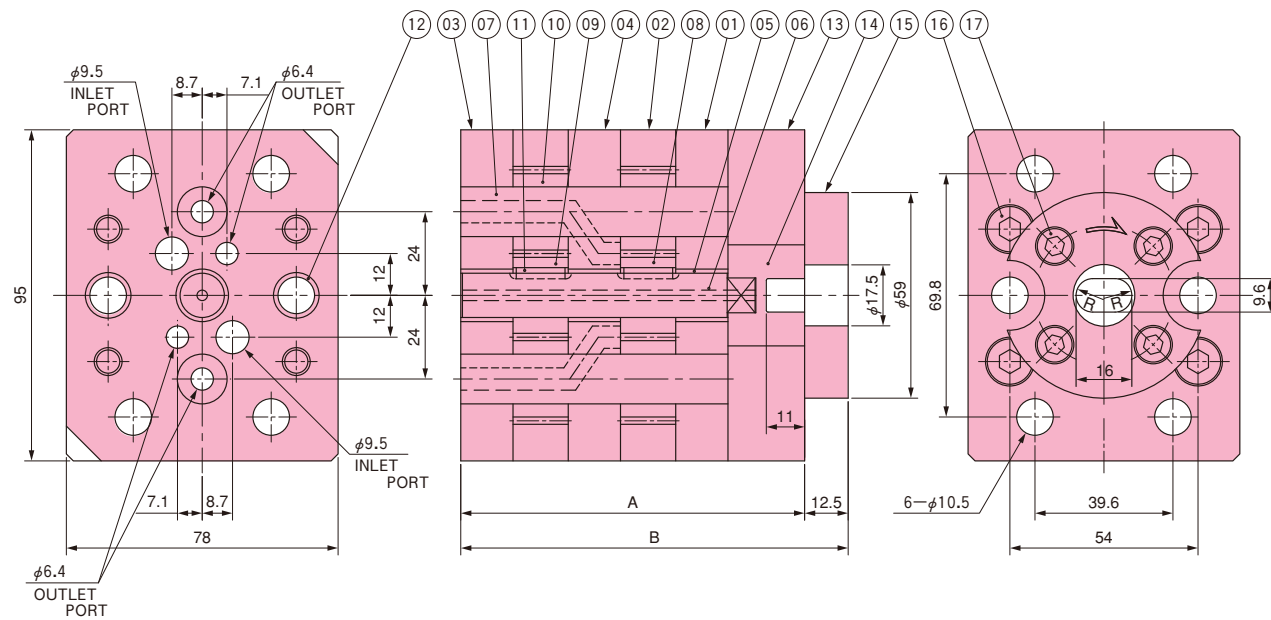

Model	Capacity (cm ³)	Diff. Press.		A	B	Mass (kg)
		MPa	kgf/cm ²			
BGTD-0.6	0.6×4	39.2	400	76.4	88.9	4.5
BGTD-0.8	0.8×4	39.2	400	79.6	92.1	4.7
BGTD-1.2	1.2×4	39.2	400	84.5	97	5
BGTD-1.6	1.6×4	39.2	400	92.1	104.6	5.5
BGTD-2.4	2.4×4	39.2	400	98.7	111.2	5.9

Parts List

Parts No.	Name	Q'ty/set
01	Front plate	1
02	Gear casing	2
03	Back plate	1
04	Middle plate	1
05	Bushing	3
06	Arbor	1
07	Stud	2
08	Driving gear	1
09	Driving gear	1
10	Driven gear	4
11	Key	2
12	Dowel	2
13	Hub	1
14	Coupler	1
15	Hub top	1
16	Plate screw	4
17	Hub screw	4

SASS SERIES



Main application : Melt spinning
 Number of ports : Inlet 1 ; Outlet 3
 Displacement / port : 0.15 ~ 4.8 cm³
 Inlet pressure : 0.5 MPa~19.6 MPa (5 kgf/cm² ~ 200 kgf/cm²)
 Outlet pressure : Max. 49.1 MPa (Max. 500 kgf/cm²)
 Differential pressure : Please refer to table as shown below.
 Temperature : Max. 350 °C
 Viscosity : Max. 400 Pa·s (Max. 4,000 Poise)
 Speed : 10 ~ 40 min⁻¹
 Standard material : High speed tool steel
 Torque list :

	Bolt size	Torque	
		N·m	kgf·cm
For plates	M6	9.8~11.8	100~120
For hub	M6	9.8~11.8	100~120
For mounting	M12	68.7~94.2	700~960

STRUCTURE DIMENSIONS (mm)

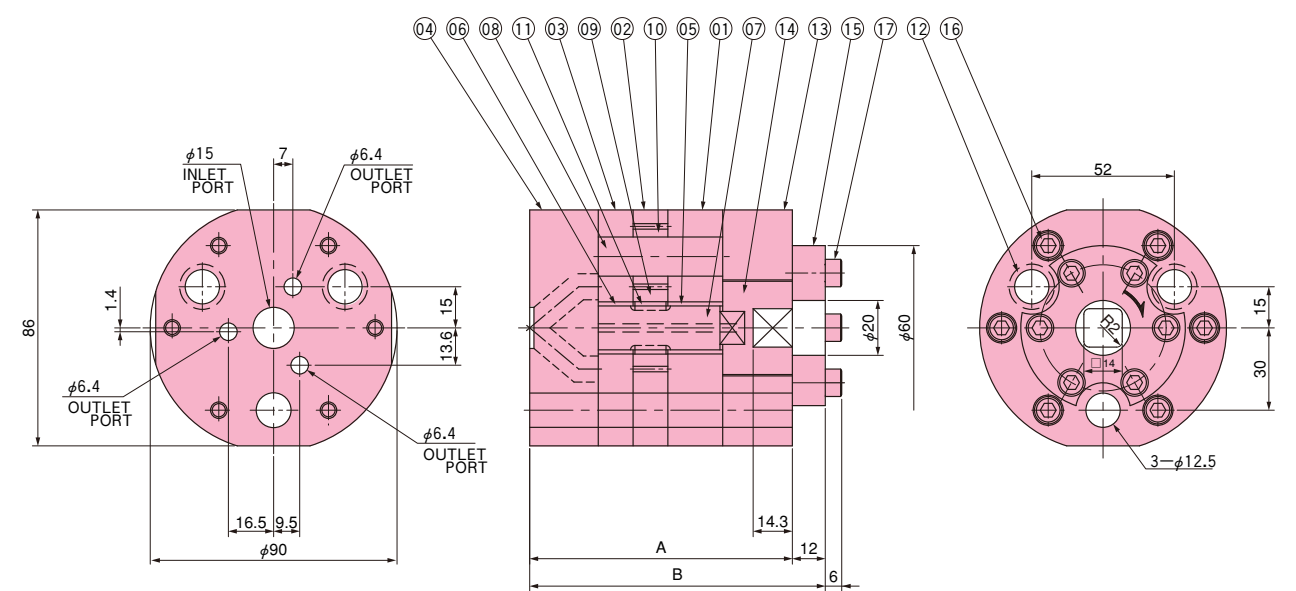

Model	Capacity (cm ³)	Diff. Press.		A	B	Mass (kg)
		MPa	kgf/cm ²			
SASS-0.15	0.15×3	39.2	400	84.7	96.7	4
SASS-0.3	0.3×3	39.2	400	86.4	98.4	4
SASS-0.6	0.6×3	39.2	400	89.6	101.6	4.2
SASS-0.8	0.8×3	39.2	400	91.8	103.8	4.3
SASS-1.2	1.2×3	39.2	400	89.5	101.5	4.2
SASS-1.6	1.6×3	39.2	400	91.6	124.3	4.3
SASS-2	2.0×3	34.3	350	93.7	105.7	4.4
SASS-2.4	2.4×3	34.3	350	95.9	107.9	4.5
SASS-3	3.0×3	34.3	350	99	111	4.7
SASS-4.8	4.8×3	29.4	300	108.5	121.2	4.9

Parts List

Parts No.	Name	Q'ty/set
01	Front plate	1
02	Gear casing	1
03	Back plate	1
04	Wear plate	1
05	Bushing	1
06	Bushing	1
07	Arbor	1
08	Stud	3
09	Driving gear	1
10	Driven gear	3
11	Key	2
12	Dowel	2
13	Hub	1
14	Coupler	1
15	Hub top	1
16	Plate screw	6
17	Hub screw	6

SADS SERIES



Main application : Melt spinning
 Number of ports : Inlet 1 ; Outlet 6
 Displacement / port : 0.15 ~ 4.8 cm³
 Inlet pressure : 0.5 MPa~19.6 MPa (5 kgf/cm² ~ 200 kgf/cm²)
 Outlet pressure : Max. 49.1 MPa (Max. 500 kgf/cm²)
 Differential pressure : Please refer to table as shown below.
 Temperature : Max. 350 °C
 Viscosity : Max. 400 Pa·s (Max. 4,000 Poise)
 Speed : 10 ~ 40 min⁻¹
 Standard material : High speed tool steel
 Torque list :

	Bolt size	Torque	
		N·m	kgf·cm
For plates	M6	9.8~11.8	100~120
For hub	M6	9.8~11.8	100~120
For mounting	M12	68.7~94.2	700~960

STRUCTURE DIMENSIONS (mm)

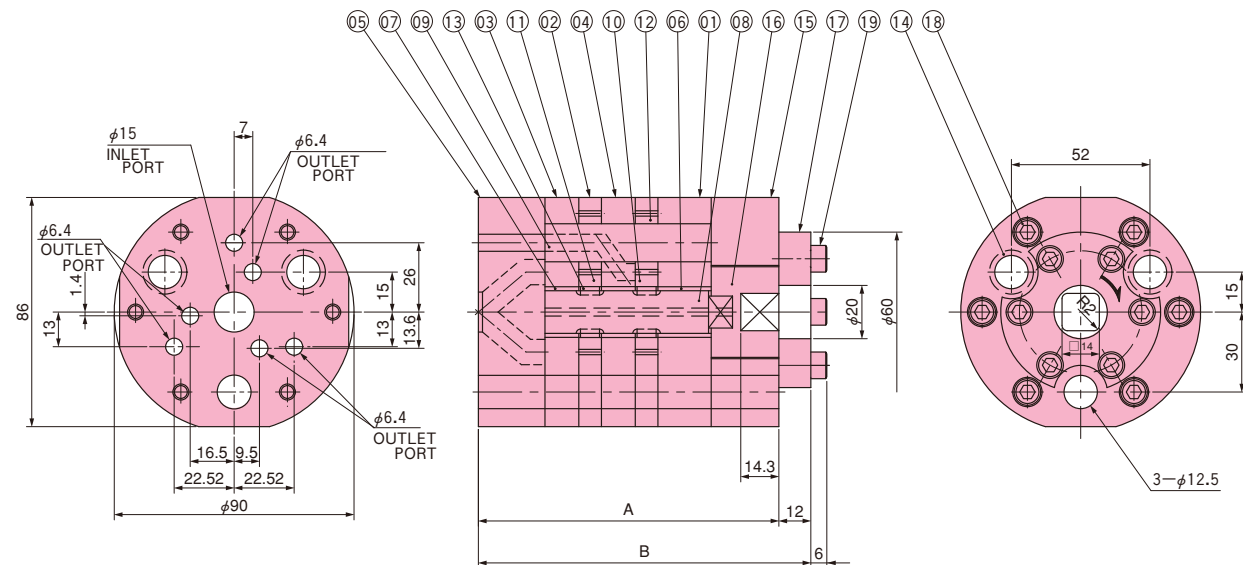

Model	Capacity (cm ³)	Diff. Press.		A	B	Mass (kg)
		MPa	kgf/cm ²			
SADS-0.15	0.15×6	39.2	400	99.1	111.1	4.6
SADS-0.3	0.3×6	39.2	400	102.3	114.3	4.8
SADS-0.6	0.6×6	39.2	400	108.8	120.8	5.2
SADS-0.8	0.8×6	39.2	400	113.2	125.2	5.4
SADS-1.2	1.2×6	39.2	400	108.5	120.5	5.1
SADS-1.6	1.6×6	29.4	300	112.8	124.8	5.4
SADS-2	2.0×6	29.4	300	117	129	5.6
SADS-2.4	2.4×6	29.4	300	121.3	133.3	5.8
SADS-3	3.0×6	24.5	250	127.6	139.6	6.1
SADS-4.8	4.8×6	24.5	250	146.6	158.6	7.2

Parts List

Parts No.	Name	Q'ty/set
01	Front plate	1
02	Gear casing	2
03	Back plate	1
04	Middle plate	1
05	Wear plate	1
06	Bushing	1
07	Bushing	2
08	Arbor	1
09	Stud	3
10	Driving gear	1
11	Driven gear	1
12	Driven gear	6
13	Key	4
14	Dowel	2
15	Hub	1
16	Coupler	1
17	Hub top	1
18	Plate screw	6
19	Hub screw	6

KH9S SERIES



Main application : Melt spinning
 Number of ports : Inlet 1 ; Outlet 4
 Displacement / port : 0.1 ~ 4.8 cm³
 Inlet pressure : 0.5 MPa~19.6 MPa (5 kgf/cm² ~ 200 kgf/cm²)
 Outlet pressure : Max. 49.1 MPa (Max. 500 kgf/cm²)
 Differential pressure : Please refer to table as shown below.
 Temperature : Max. 350 °C
 Viscosity : Max. 400 Pa·s (Max. 4,000 Poise)
 Speed : 10 ~ 40 min⁻¹
 Standard material : High speed tool steel
 Torque list :

	Bolt size	Torque	
		N·m	kgf·cm
For plates	M6	9.8~11.8	100~120
For hub	M6	9.8~11.8	100~120
For mounting	M12	68.7~94.2	700~960

STRUCTURE DIMENSIONS (mm)

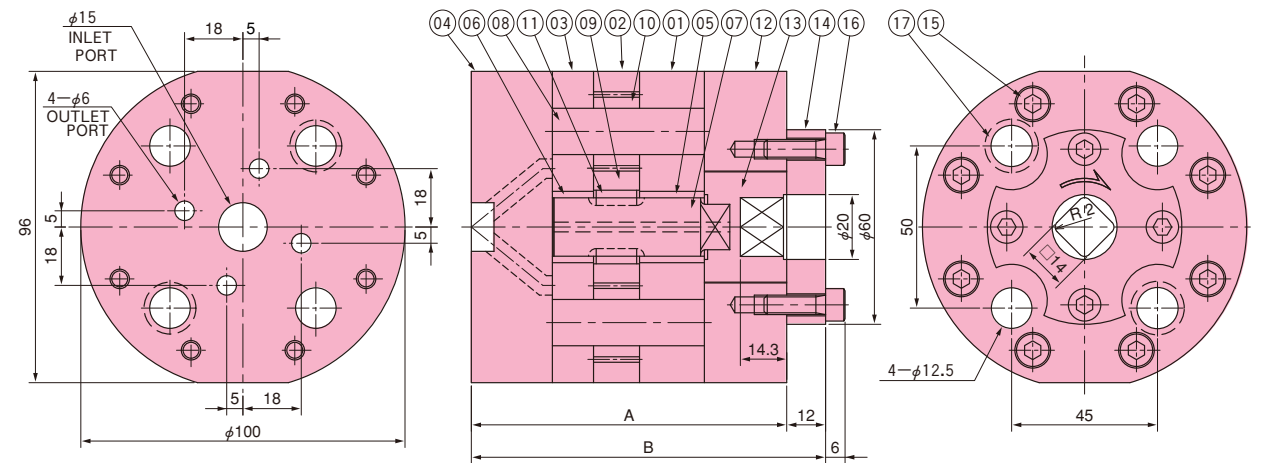

Model	Capacity (cm ³)	Diff. Press.		A	B	Mass (kg)
		MPa	kgf/cm ²			
KH9S-0.1	0.1×4	39.2	400	85	97	5.3
KH9S-0.15	0.15×4	39.2	400	85	97	5.3
KH9S-0.3	0.3×4	39.2	400	86.9	98.9	5.4
KH9S-0.6	0.6×4	39.2	400	88.4	100.4	5.5
KH9S-1	1.0×4	39.2	400	91.9	103.9	5.7
KH9S-1.2	1.2×4	39.2	400	93.7	105.7	5.8
KH9S-1.6	1.6×4	39.2	400	97.3	109.3	6.1
KH9S-1.8	1.8×4	39.2	400	99.1	111.1	6.1
KH9S-2	2.0×4	39.2	400	100.8	112.8	6.2
KH9S-2.4	2.4×4	39.2	400	96.3	108.3	6.7
KH9S-3	3.0×4	39.2	400	99.6	111.6	6.2
KH9S-4	4.0×4	29.4	300	100.1	112.1	6.2
KH9S-4.8	4.8×4	29.4	300	103.3	115.3	6.4

Parts List

Parts No.	Name	Q'ty/set
01	Front plate	1
02	Gear casing	1
03	Back plate	1
04	Wear plate	1
05	Bushing	1
06	Bushing	1
07	Arbor	1
08	Stud	4
09	Driving gear	1
10	Driven gear	4
11	Key	2
12	Hub	1
13	Coupler	1
14	Hub top	1
15	Plate screw	8
16	Hub screw	4
17	Dowel	2

KH9D SERIES



Main application : Melt spinning
 Number of ports : Inlet 1 ; Outlet 8
 Displacement / port : 0.1 ~ 3 cm³
 Inlet pressure : 0.5 MPa~19.6 MPa (5 kgf/cm² ~ 200 kgf/cm²)
 Outlet pressure : Max. 49.1 MPa (Max. 500 kgf/cm²)
 Differential pressure : Please refer to table as shown below.
 Temperature : Max. 350 °C
 Viscosity : Max. 400 Pa·s (Max. 4,000 Poise)
 Speed : 10 ~ 40 min⁻¹
 Standard material : High speed tool steel
 Torque list :

	Bolt size	Torque	
		N·m	kgf·cm
For plates	M6	9.8~11.8	100~120
For hub	M6	9.8~11.8	100~120
For mounting	M12	68.7~94.2	700~960

STRUCTURE DIMENSIONS (mm)

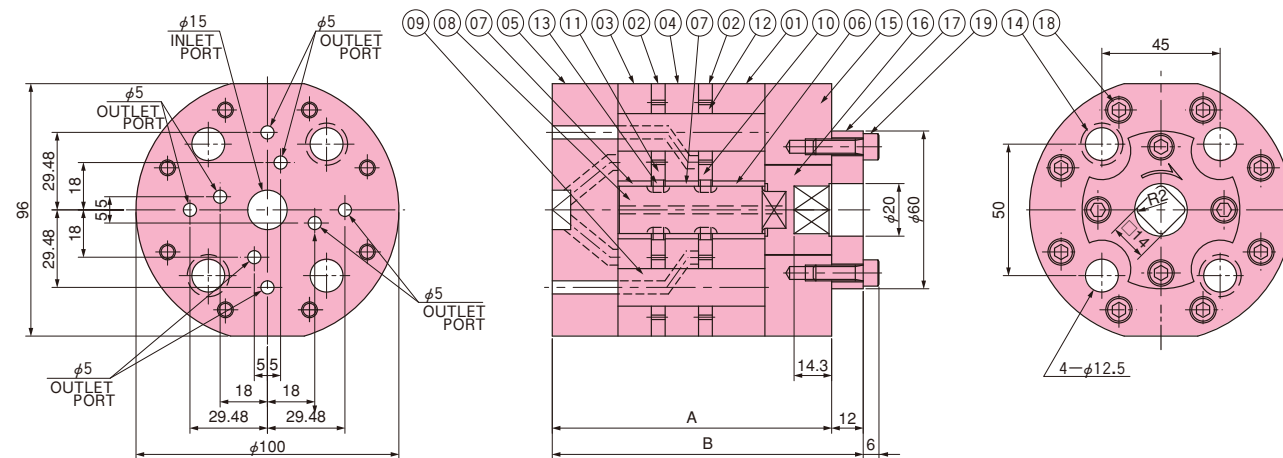

Model	Capacity (cm ³)	Diff. Press.		A	B	Mass (kg)
		MPa	kgf/cm ²			
KH9D-0.1	0.1×8	39.2	400	99.6	111.6	5.7
KH9D-0.15	0.15×8	39.2	400	99.6	111.6	5.7
KH9D-0.3	0.3×8	39.2	400	103.5	115.5	6
KH9D-0.6	0.6×8	39.2	400	106.3	118.3	6.2
KH9D-0.8	0.8×8	39.2	400	109.8	121.8	6.4
KH9D-1.2	1.2×8	34.3	350	117.1	129.1	6.9
KH9D-1.6	1.6×8	34.3	350	124.2	136.2	7.3
KH9D-2	2.0×8	29.4	300	131.3	143.3	7.8
KH9D-2.4	2.4×8	24.5	250	122.2	134.2	7.2
KH9D-3	3.0×8	24.5	250	128.8	140.8	7.7

Parts List

Parts No.	Name	Q'ty/set
01	Front plate	1
02	Gear casing	2
03	Back plate	1
04	Middle plate	1
05	Wear plate	1
06	Bushing	1
07	Bushing	2
08	Arbor	1
09	Stud	4
10	Driving gear	1
11	Driving gear	1
12	Driven gear	8
13	Key	4
14	Dowel	2
15	Hub	1
16	Coupler	1
17	Hub top	1
18	Plate screw	8
19	Hub screw	4

KH15S/KH15D SERIES

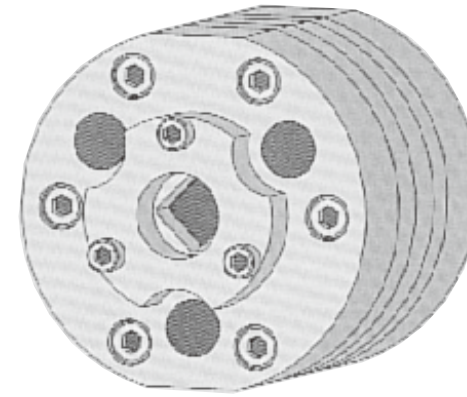

Main application : Melt spinning
 Number of ports : Inlet 1 ; Outlet 3 (KH15S), 6 (KH15D)
 Displacement / port : 3 ~ 6 cm³
 Inlet pressure : 0.5 MPa~19.6 MPa (5 kgf/cm² ~ 200 kgf/cm²)
 Outlet pressure : Max. 49.1 MPa (Max. 500 kgf/cm²)
 Differential pressure : Please refer to table as shown below.
 Temperature : Max. 350 °C
 Viscosity : Max. 400 Pa·s (Max. 4,000 Poise)
 Speed : 10 ~ 40 min⁻¹
 Standard material : High speed tool steel
 Torque list :

	Bolt size	Torque	
		N·m	kgf·cm
For plates	M8	24.5~27.5	250~280
For hub	M6	9.8~11.8	100~120
For mounting	M16	225.6~245.3	2,300~2,500

STRUCTURE DIMENSIONS (mm)

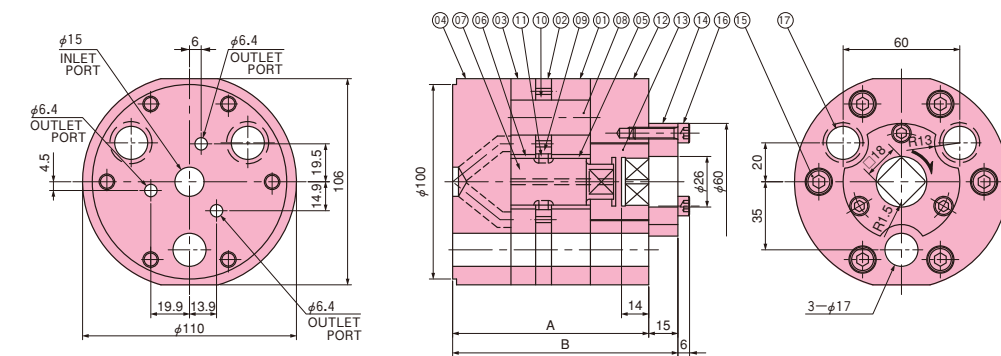

Model	Capacity (cm ³)	Diff. Press.		A	B	Mass (kg)
		MPa	kgf/cm ²			
KH15S-3	3×3	39.2	400	100.9	115.9	7.6
KH15S-6	6×3	39.2	400	109	124	7.9

Parts List

Parts No.	Name	Q'ty/set
01	Front plate	1
02	Gear casing	1
03	Back plate	1
04	Wear plate	1
05	Bushing	1
06	Bushing	1
07	Arbor	1
08	Stud	3
09	Driving gear	1
10	Driven gear	3
11	Key	2
12	Hub	1
13	Coupler	1
14	Hub top	1
15	Plate screw	6
16	Hub screw	3
17	Dowel	2

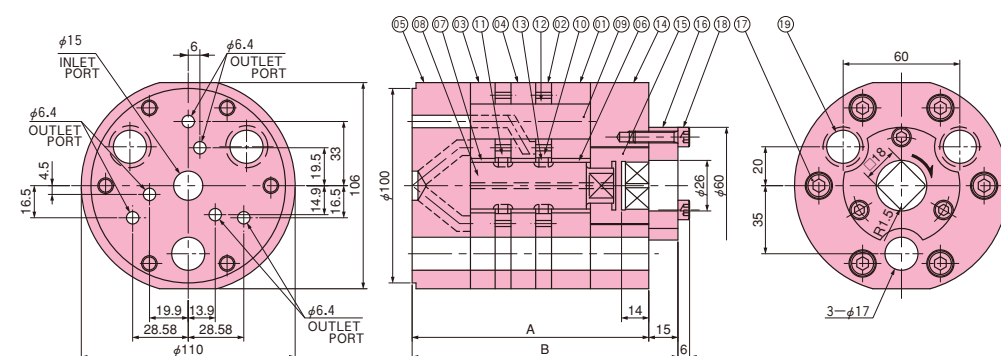

Model	Capacity (cm ³)	Diff. Press.		A	B	Mass (kg)
		MPa	kgf/cm ²			
KH15D-3	3×6	34.3	350	121.7	136.7	9.5
KH15D-6	6×6	29.4	300	138	163	10.1

Parts List

Parts No.	Name	Q'ty/set
01	Front plate	1
02	Gear casing	2
03	Back plate	1
04	Middle plate	1
05	Wear plate	1
06	Bushing	1
07	Bushing	2
08	Arbor	1
09	Stud	3
10	Driving gear	1
11	Driving gear	1
12	Driven gear	6
13	Key	4
14	Hub	1
15	Coupler	1
16	Hub top	1
17	Plate screw	6
18	Hub screw	3
19	Dowel	2

KH13S SERIES

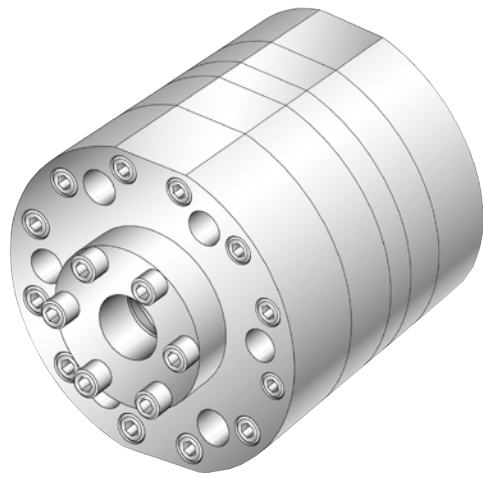

Main application : Melt spinning
 Number of ports : Inlet 1 ; Outlet 6
 Displacement / port : 0.3 ~ 6 cm³
 Inlet pressure : 0.5 MPa~19.6 MPa (5 kgf/cm² ~ 200 kgf/cm²)
 Outlet pressure : Max. 49.1 MPa (Max. 500 kgf/cm²)
 Differential pressure : Please refer to table as shown below.
 Temperature : Max. 350 °C
 Viscosity : Max. 400 Pa·s (Max. 4,000 Poise)
 Speed : 10 ~ 40 min⁻¹
 Standard material : High speed tool steel
 Torque list :

	Bolt size	Torque	
		N·m	kgf·cm
For plates	M8	9.8 ~ 11.8	100 ~ 120
For hub	M6	9.8 ~ 11.8	100 ~ 120
For mounting	M12	68.7 ~ 94.2	700 ~ 960

STRUCTURE DIMENSIONS (mm)

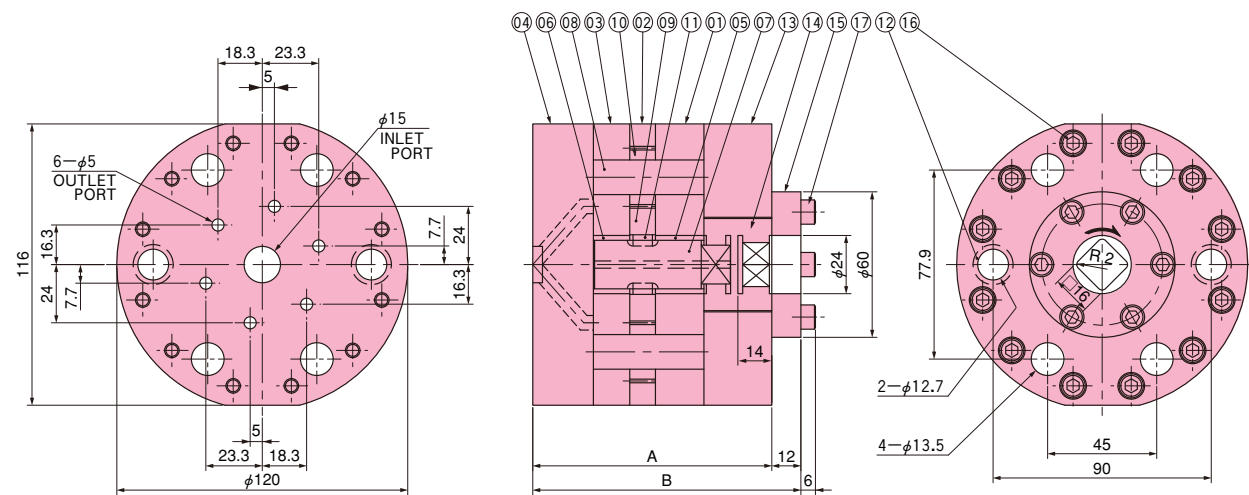

Model	Capacity (cm ³)	Diff. Press.		A	B	Mass (kg)
		MPa	kgf/cm ²			
KH13S-0.3	0.3×6	39.2	400	92	104	8.2
KH13S-0.6	0.6×6	39.2	400	95.9	107.9	8.5
KH13S-0.8	0.8×6	39.2	400	91.8	103.8	8.2
KH13S-1.2	1.2×6	34.3	350	93.3	105.3	8.3
KH13S-1.6	1.6×6	34.3	350	95.1	107.1	8.4
KH13S-2	2.0×6	29.4	300	96.8	108.8	8.6
KH13S-2.4	2.4×6	24.5	250	98.6	110.6	8.8
KH13S-3	3.0×6	24.5	250	101.3	113.3	9.0
KH13S-3.5	3.5×6	24.5	250	103.5	115.5	9.2
KH13S-4.8	4.8×6	24.5	250	109.2	121.2	9.7
KH13S-6	6.0×6	24.5	250	107.9	119.9	9.6

Parts List

Parts No.	Name	Q'ty/set
01	Front plate	1
02	Gear casing	1
03	Back plate	1
04	Wear plate	1
05	Bushing	1
06	Bushing	1
07	Arbor	1
08	Stud	6
09	Driving gear	1
10	Driven gear	6
11	Key	2
12	Dowel	2
13	Hub	1
14	Coupler	1
15	Hub top	1
16	Plate screw	12
17	Hub screw	6

KH13D SERIES

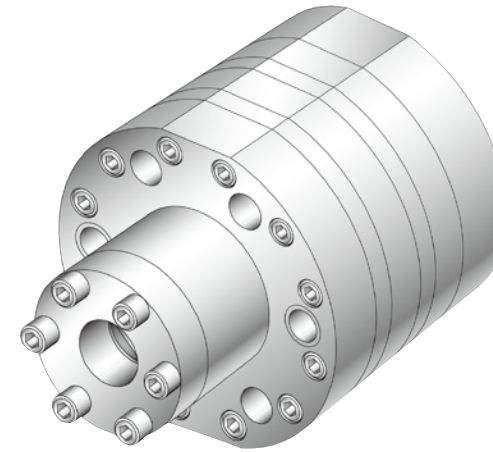

Main application : Melt & dry spinning
 Number of ports : Inlet 1 ; Outlet 12
 Displacement / port : 0.3 ~ 2 cm³
 Inlet pressure : 0.5 MPa~ 4.9 MPa (5 kgf/cm² ~ 50 kgf/cm²)
 Outlet pressure : Max. 19.6 MPa (Max. 200 kgf/cm²)
 Differential pressure : Please refer to table as shown below.
 Temperature : Max. 350 °C
 Viscosity : Max. 400 Pa·s (Max. 4,000 Poise)
 Speed : 5 ~ 40 min⁻¹
 Standard material : High speed tool steel
 Torque list :

	Bolt size	Torque	
		N·m	kgf·cm
For plates	M6	9.8 ~ 11.8	100 ~ 120
For hub	M6	9.8 ~ 11.8	100 ~ 120
For mounting	M12	68.7 ~ 94.2	700 ~ 960

STRUCTURE DIMENSIONS (mm)

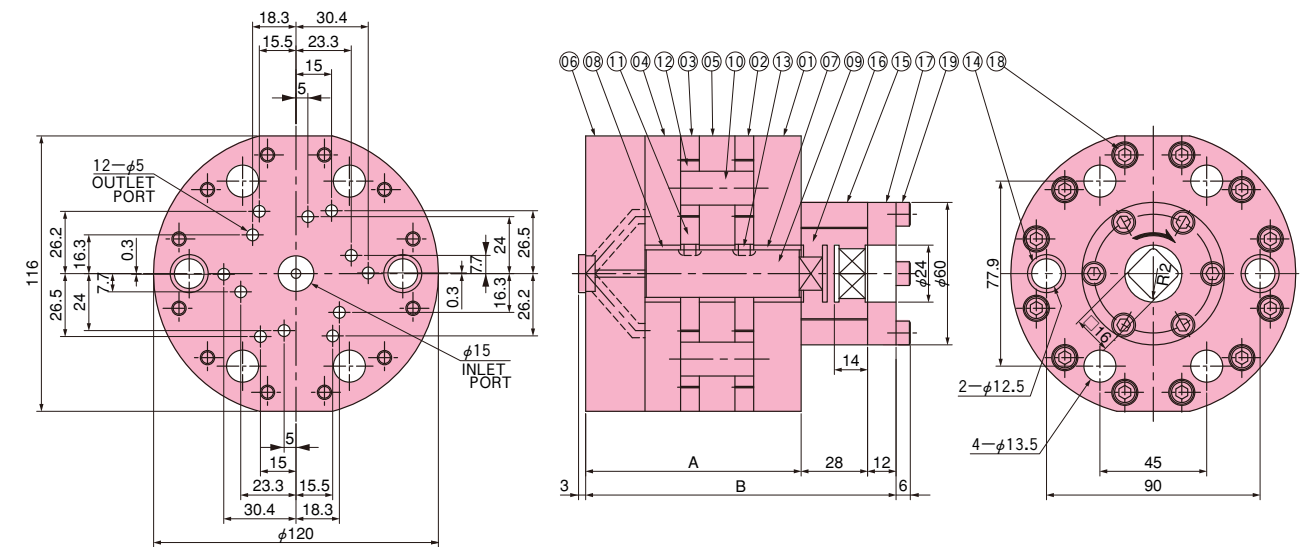

Model	Capacity (cm ³)	Diff. Press.		A	B	Mass (kg)
		MPa	kgf/cm ²			
KH13D-0.3	0.3×12	19.6	200	82.9	122.9	8.4
KH13D-0.6	0.6×12	19.6	200	90.8	130.8	9
KH13D-0.8	0.8×12	19.6	200	82.1	122.1	8.4
KH13D-1.0	1.0×12	19.6	200	83.8	123.8	8.5
KH13D-1.2	1.2×12	19.6	200	85.6	125.6	8.6
KH13D-2	2.0×12	19.6	200	92.6	132.6	9.2

Parts List

Parts No.	Name	Q'ty/set
01	Front plate	1
02	Gear casing	1
03	Gear casing	1
04	Back plate	1
05	Middle plate	1
06	Wear plate	1
07	Bushing	1
08	Bushing	2
09	Arbor	1
10	Stud	6
11	Driving gear	2
12	Driven gear	12
13	Key	2
14	Dowel	2
15	Hub	1
16	Coupler	1
17	Hub top	1
18	Plate screw	12
19	Hub screw	6

KH17S SERIES

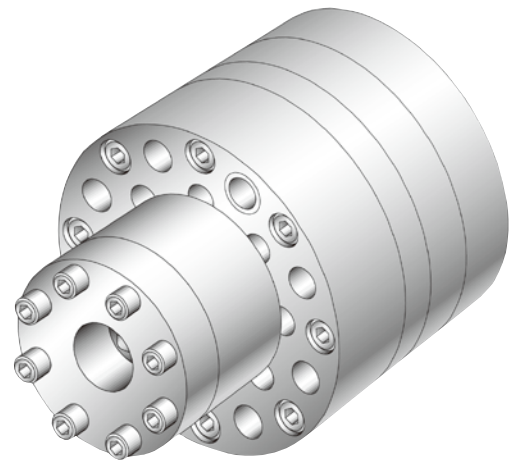

Main application : Melt spinning
 Number of ports : Inlet 1 ; Outlet 8
 Displacement / port : 0.8 ~ 3 cm³
 Inlet pressure : 0.5 MPa~19.6 MPa (5 kgf/cm² ~ 200 kgf/cm²)
 Outlet pressure : Max. 49.1 MPa (Max. 500 kgf/cm²)
 Differential pressure : Please refer to table as shown below.
 Temperature : Max. 350 °C
 Viscosity : Max. 400 Pa·s (Max. 4,000 Poise)
 Speed : 10 ~ 30 min⁻¹
 Standard material : High speed tool steel
 Torque list :

	Bolt size	Torque	
		N·m	kgf·cm
For plates	M8	24.5 ~ 27.5	250 ~ 280
For hub	M6	9.8 ~ 11.8	100 ~ 120
For mounting	M12	68.7 ~ 94.2	700 ~ 960

STRUCTURE DIMENSIONS (mm)

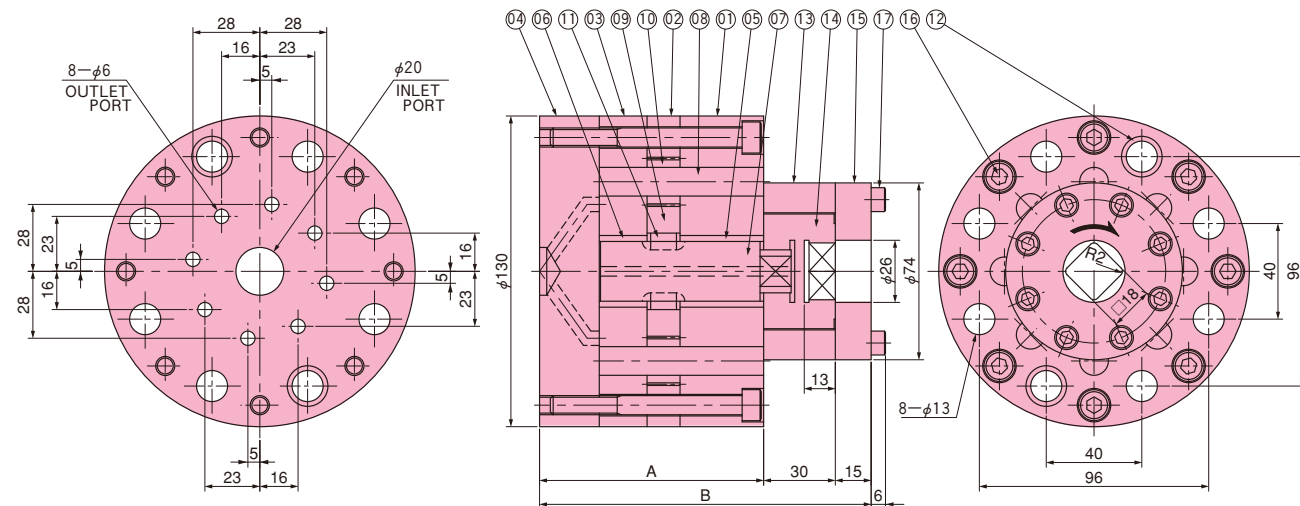

Model	Capacity (cm ³)	Diff. Press.		A	B	Mass (kg)
		MPa	kgf/cm ²			
KH17S-0.8	0.8×8	39.2	400	84.6	129.6	10.3
KH17S-1.2	1.2×8	39.2	400	86.9	131.9	10.6
KH17S-2.4	2.4×8	39.2	400	93.8	138.8	11.3
KH17S-3	3.0×8	39.2	400	97.2	142.2	11.6

Parts List

Parts No.	Name	Q'ty/set
01	Front plate	1
02	Gear casing	1
03	Back plate	1
04	Wear plate	1
05	Bushing	1
06	Bushing	1
07	Arbor	1
08	Stud	6
09	Driving gear	1
10	Driven gear	6
11	Key	2
12	Dowel	2
13	Hub	1
14	Coupler	1
15	Hub top	1
16	Plate screw	8
17	Hub screw	8

SBSS SERIES

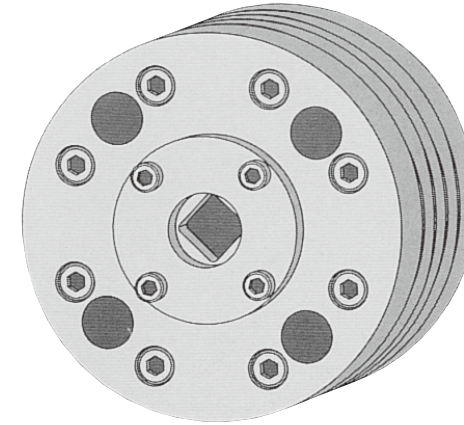

Main application : Melt spinning
 Number of ports : Inlet 1 ; Outlet 4
 Displacement / port : 4 ~ 7 cm³
 Inlet pressure : 0.5 MPa~19.6 MPa (5 kgf/cm² ~ 200 kgf/cm²)
 Outlet pressure : Max. 49.1 MPa (Max. 500 kgf/cm²)
 Differential pressure : Please refer to table as shown below.
 Temperature : Max. 350 °C
 Viscosity : Max. 400 Pa·s (Max. 4,000 Poise)
 Speed : 10 ~ 40 min⁻¹
 Standard material : High speed tool steel
 Torque list :

	Bolt size	Torque	
		N·m	kgf·cm
For plates	M8	24.5 ~ 27.5	250 ~ 280
For hub	M6	9.8 ~ 11.8	100 ~ 120
For mounting	M16	225.6 ~ 245.3	2,300 ~ 2,500

STRUCTURE DIMENSIONS (mm)

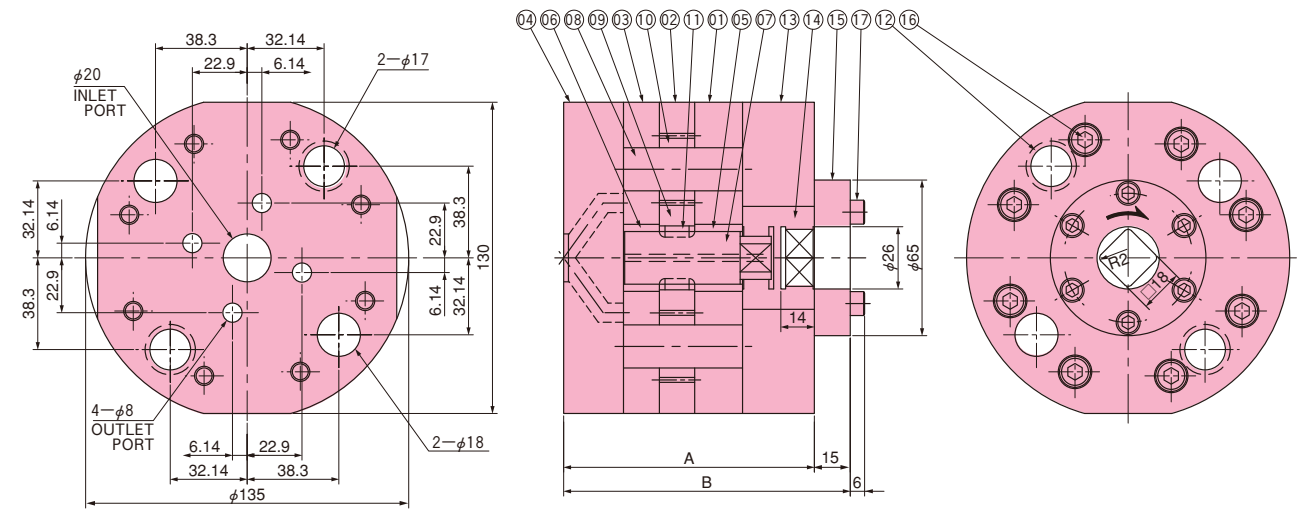

Model	Capacity (cm ³)	Diff. Press.		A	B	Mass (kg)
		MPa	kgf/cm ²			
SBSS-4	4×4	39.2	400	108.8	118.8	12.4
SBSS-5	5×4	39.2	400	112.3	122.3	12.8
SBSS-6	6×4	39.2	400	115.7	125.7	13.3
SBSS-7	7×4	39.2	400	119.2	129.2	13.6

Parts List

Parts No.	Name	Q'ty/set
01	Front plate	1
02	Gear casing	1
03	Back plate	1
04	Wear plate	1
05	Bushing	1
06	Bushing	1
07	Arbor	1
08	Stud	4
09	Driving gear	1
10	Driven gear	4
11	Key	2
12	Dowel	2
13	Hub	1
14	Coupler	1
15	Hub top	1
16	Plate screw	8
17	Hub screw	6

KH11D SERIES

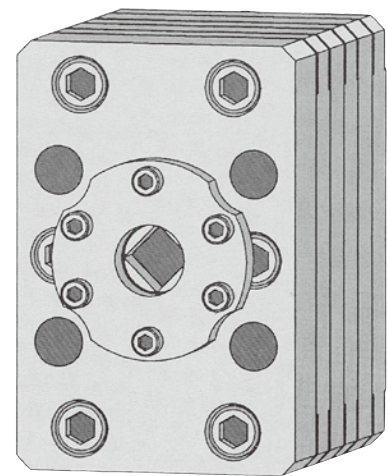

Main application : Melt spinning
 Number of ports : Inlet 2 ; Outlet 4
 Displacement / port : 5 ~ 15 cm³
 Inlet pressure : 0.5 MPa~19.6 MPa (5 kgf/cm² ~ 200 kgf/cm²)
 Outlet pressure : Max. 49.1 MPa (Max. 500 kgf/cm²)
 Differential pressure : Please refer to table as shown below.
 Temperature : Max. 350 °C
 Viscosity : Max. 400 Pa·s (Max. 4,000 Poise)
 Speed : 10 ~ 40 min⁻¹
 Standard material : High speed tool steel
 Torque list :

	Bolt size	Torque	
		N·m	kgf·cm
For plates	M12	88.3 ~ 94.2	900 ~ 960
For hub	M6	9.8 ~ 11.8	100 ~ 120
For mounting	M16	225.6 ~ 245.3	2,300 ~ 2,500

STRUCTURE DIMENSIONS (mm)

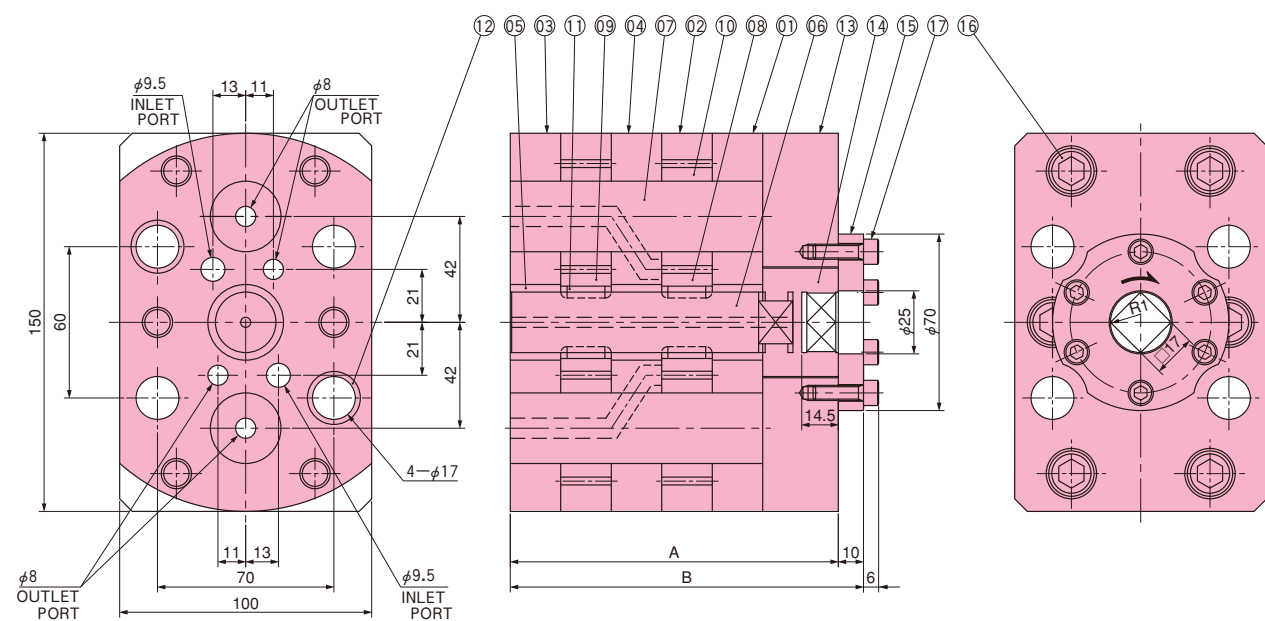

Model	Capacity (cm ³)	Diff. Press.		A	B	Mass (kg)
		MPa	kgf/cm ²			
KH11D-5	5×4	39.2	400	115.3	125.3	13.8
KH11D-8	8×4	39.2	400	130.2	140.2	15.6
KH11D-10	10×4	34.3	350	140.2	150.2	16.8
KH11D-15	15×4	29.4	300	146.8	156.8	17.5

Parts List

Parts No.	Name	Q'ty/set
01	Front plate	1
02	Gear casing	2
03	Back plate	1
04	Middle plate	1
05	Bushing	3
06	Arbor	1
07	Stud	2
08	Driving gear	1
09	Driving gear	1
10	Driven gear	4
11	Key	4
12	Dowel	2
13	Hub	1
14	Coupler	1
15	Hub top	1
16	Plate screw	6
17	Hub screw	6

BAS SERIES

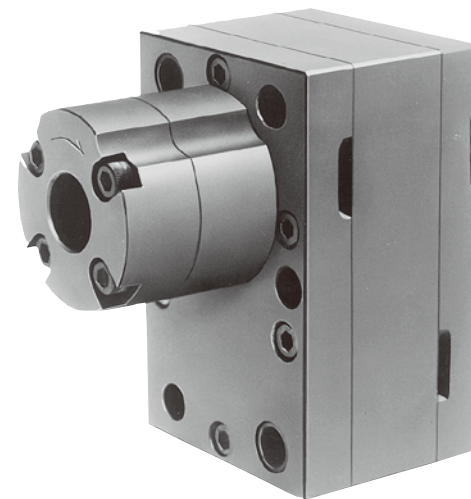

Main application : Melt spinning
 Number of ports : Inlet 1 ; Outlet 1
 Displacement / port : 5 ~ 30 cm³
 Inlet pressure : 0.5 MPa~9.8 MPa (5 kgf/cm² ~ 100 kgf/cm²)
 Outlet pressure : Max. 19.6 MPa (Max. 200 kgf/cm²)
 Differential pressure : Please refer to table as shown below.
 Temperature : Max. 350 °C
 Viscosity : Max. 400 Pa·s (Max. 4,000 Poise)
 Speed : 10 ~ 40 min⁻¹
 Standard material : Alloy tool steel
 Torque list :

	Bolt size	Torque	
		N·m	kgf·cm
For plates	M6	9.8 ~ 11.8	100 ~ 120
For hub	M6	9.8 ~ 11.8	100 ~ 120
For mounting	M10	49.1 ~ 53.9	500 ~ 550

STRUCTURE DIMENSIONS (mm)

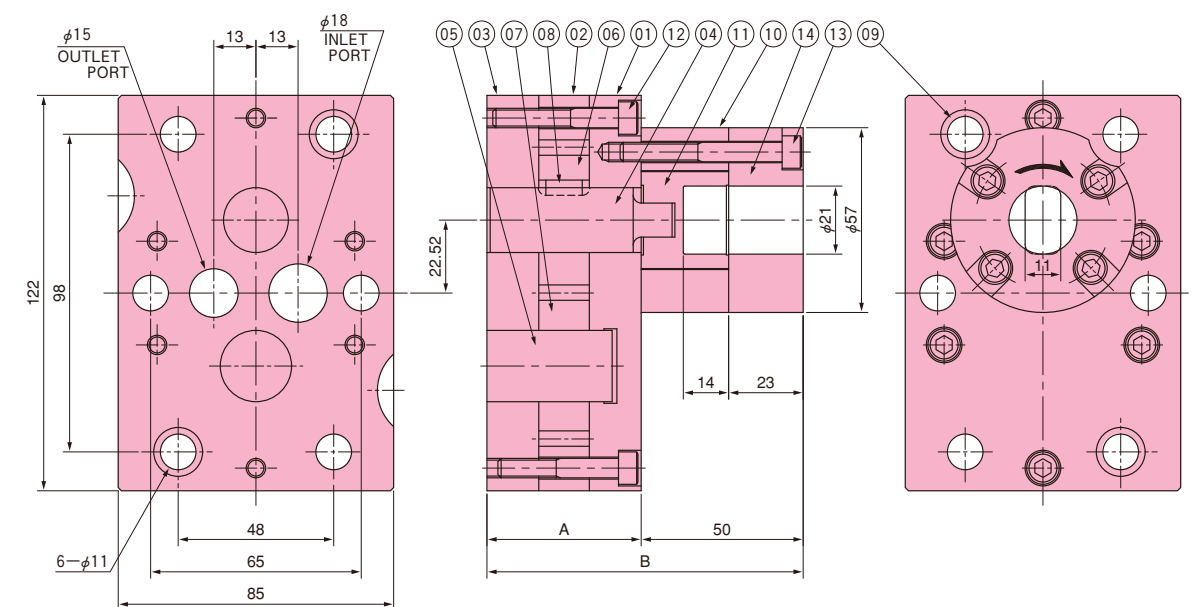

Model	Capacity (cm ³)	Diff. Press.		A	B	Mass (kg)
		MPa	kgf/cm ²			
BAS-5	5	19.6	200	39.8	89.8	4.3
BAS-7.2	7.2	19.6	200	43.3	93.3	4.6
BAS-10	10	19.6	200	47.6	97.6	5
BAS-12	12	14.7	150	50.7	100.7	5.2
BAS-15	15	14.7	150	55.4	105.4	5.6
BAS-20	20	9.8	100	63.2	113.2	6.3
BAS-30	30	9.8	100	78.8	128.8	7.6

Parts List

Parts No.	Name	Q'ty/set
01	Front plate	1
02	Gear casing	1
03	Back plate	1
04	Arbor	1
05	Stud	1
06	Driving gear	1
07	Driven gear	1
08	Key	1
09	Dowel	2
10	Hub	1
11	Coupler	1
12	Plate screw	6
13	Hub screw	4
14	Hub top	1

BAS-H SERIES

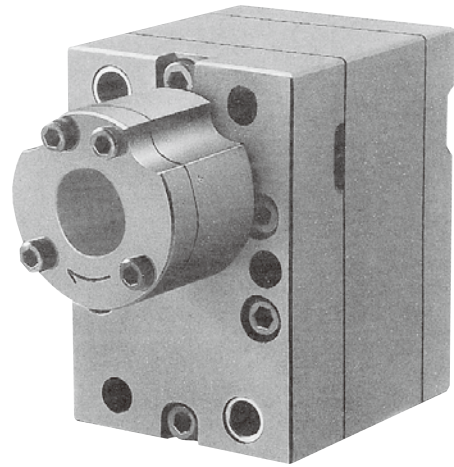

Main application : Melt spinning
 Number of ports : Inlet 1 ; Outlet 1
 Displacement / port : 5 ~ 30 cm³
 Inlet pressure : 0.5 MPa~19.6 MPa (5 kgf/cm² ~ 200 kgf/cm²)
 Outlet pressure : Max. 49.1 MPa (Max. 500 kgf/cm²)
 Differential pressure : Please refer to table as shown below.
 Temperature : Max. 350 °C
 Viscosity : Max. 400 Pa·s (Max. 4,000 Poise)
 Speed : 10 ~ 40 min⁻¹
 Standard material : High speed tool steel
 Torque list :

	Bolt size	Torque	
		N·m	kgf·cm
For plates	M8	24.5 ~ 27.5	250 ~ 280
For hub	M6	9.8 ~ 11.8	100 ~ 120
For mounting	M10	49.1 ~ 53.9	500 ~ 550

STRUCTURE DIMENSIONS (mm)

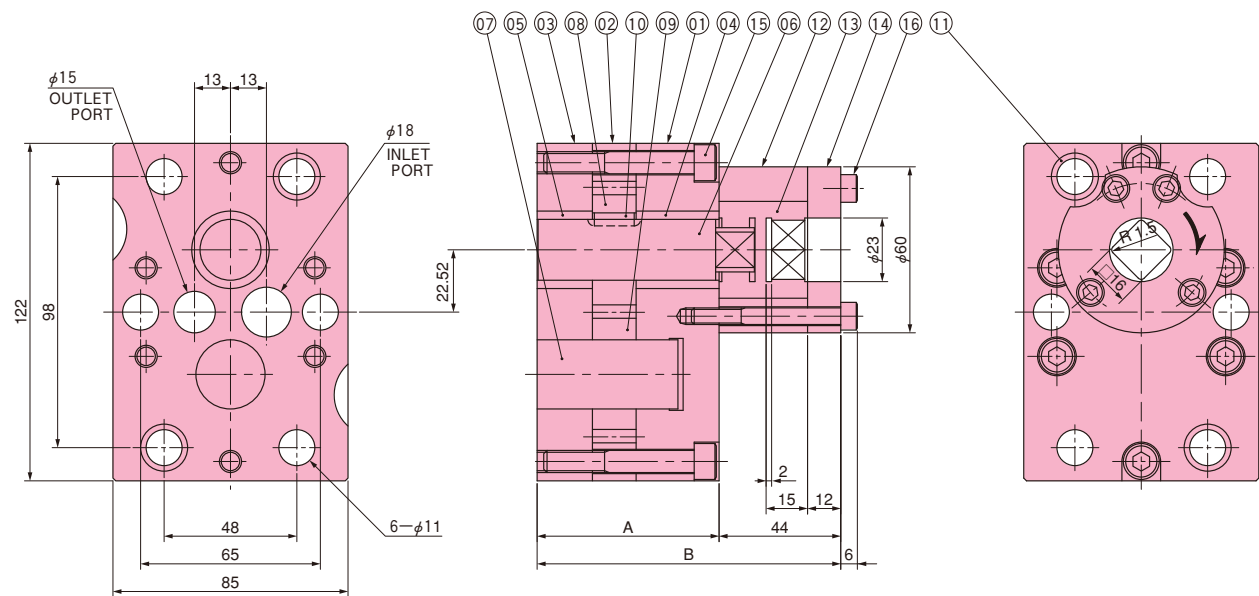

Model	Capacity (cm ³)	Diff. Press.		A	B	Mass (kg)
		MPa	kgf/cm ²			
BAS-5-H	5	39.2	400	57.9	101.9	5.8
BAS-7.2-H	7.2	39.2	400	61.4	105.4	6
BAS-10-H	10	39.2	400	65.8	109.8	6.4
BAS-12-H	12	34.3	350	69	113	6.7
BAS-15-H	15	34.3	350	73.7	117.7	7
BAS-20-H	20	29.4	300	81.6	125.6	7.7
BAS-30-H	30	24.5	250	97.4	141.4	9

Parts List

Parts No.	Name	Q'ty/set
01	Front plate	1
02	Gear casing	1
03	Back plate	1
04	Bushing	1
05	Bushing	1
06	Arbor	1
07	Stud	1
08	Driving gear	1
09	Driven gear	1
10	Key	1
11	Dowel	2
12	Hub	1
13	Coupler	1
14	Hub top	1
15	Plate screw	6
16	Hub screw	4

KH2-H SERIES

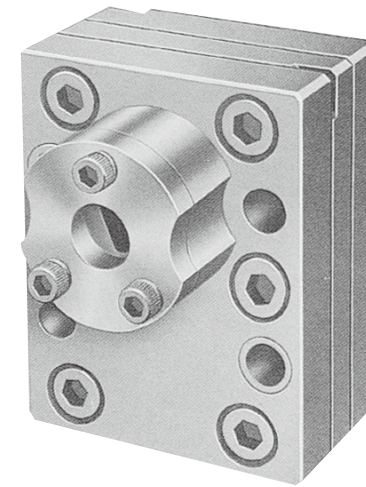

Main application : Melt spinning
 Number of ports : Inlet 1 ; Outlet 1
 Displacement / port : 3 ~ 40 cm³
 Inlet pressure : 0.5 MPa~19.6 MPa (5 kgf/cm² ~ 200 kgf/cm²)
 Outlet pressure : Max. 49.1 MPa (Max. 500 kgf/cm²)
 Differential pressure : Please refer to table as shown below.
 Temperature : Max. 350 °C
 Viscosity : Max. 400 Pa·s (Max. 4,000 Poise)
 Speed : 10 ~ 40 min⁻¹
 Standard material : High speed tool steel
 Torque list :

	Bolt size	Torque	
		N·m	kgf·cm
For plates	1/2-13UNC	107.9 ~ 117.7	1,100 ~ 1,200
For hub	5/16-18UNC	21.6 ~ 24.5	220 ~ 250
For mounting	M12	88.3 ~ 94.2	900 ~ 960

STRUCTURE DIMENSIONS (mm)

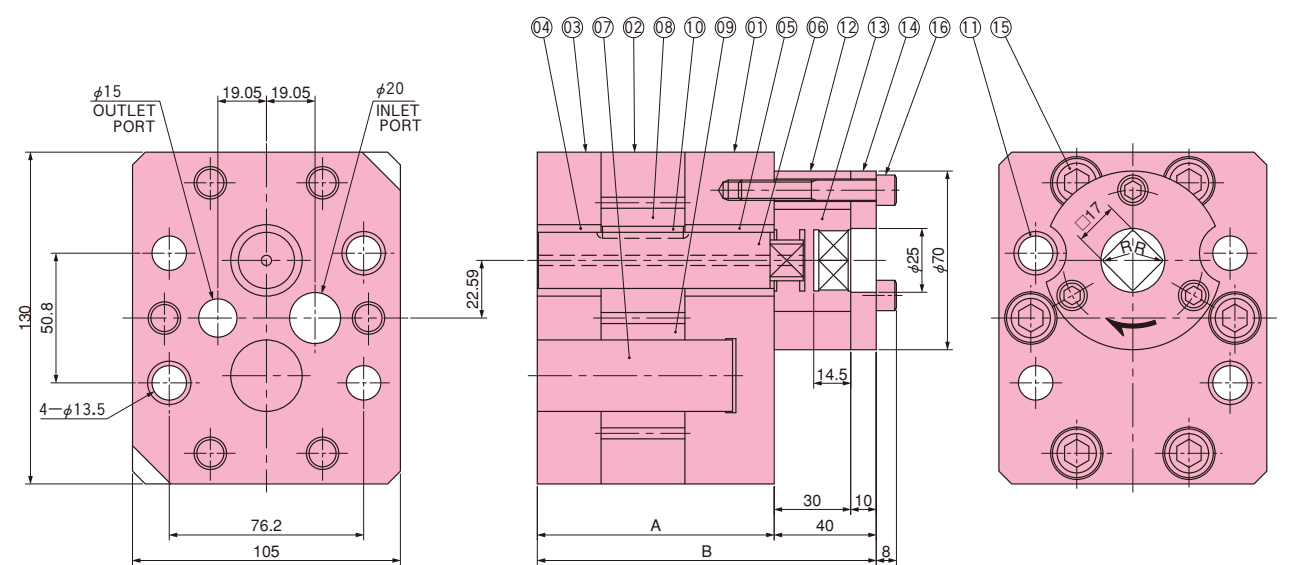

Model	Capacity (cm ³)	Diff. Press.		A	B	Mass (kg)
		MPa	kgf/cm ²			
KH2-3-H	3	39.2	400	64.9	104.9	8.3
KH2-5-H	5	39.2	400	68.2	108.2	8.7
KH2-10-H	10	39.2	400	76.4	116.4	9.6
KH2-15-H	15	39.2	400	84.7	124.7	10.5
KH2-20-H	20	39.2	400	92.9	132.9	11.4
KH2-25-H	25	29.4	300	100.8	140.8	12.2
KH2-30-H	30	24.5	250	109.2	149.2	13.1
KH2-40-H	40	24.5	250	107	147	12.9

Parts List

Parts No.	Name	Q'ty/set
01	Front plate	1
02	Gear casing	1
03	Back plate	1
04	Bushing	1
05	Bushing	1
06	Arbor	1
07	Stud	1
08	Driving gear	1
09	Driven gear	1
10	Key	1
11	Dowel	2
12	Hub	1
13	Coupler	1
14	Hub top	1
15	Plate screw	6
16	Hub screw	3

KH2D-H SERIES

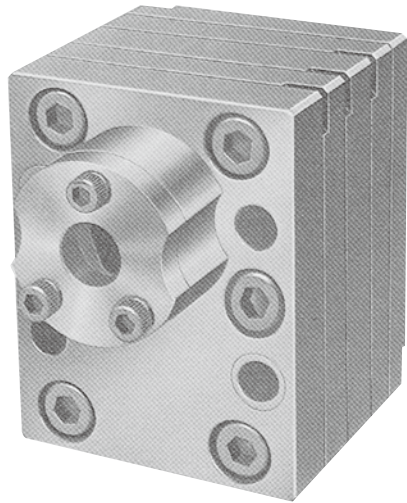

Main application : Melt spinning
 Number of ports : Inlet 1 ; Outlet 2
 Displacement / port : 3 ~ 20 cm³
 Inlet pressure : 0.5 MPa~19.6 MPa (5 kgf/cm² ~ 200 kgf/cm²)
 Outlet pressure : Max. 49.1 MPa (Max. 500 kgf/cm²)
 Differential pressure : Please refer to table as shown below.
 Temperature : Max. 350 °C
 Viscosity : Max. 400 Pa·s (Max. 4,000 Poise)
 Speed : 10 ~ 40 min⁻¹
 Standard material : High speed tool steel
 Torque list :

	Bolt size	Torque	
		N·m	kgf·cm
For plates	1/2-13UNC	107.9 ~ 117.7	1,100 ~ 1,200
For hub	5/16-18UNC	21.6 ~ 24.5	220 ~ 250
For mounting	M12	88.3 ~ 94.2	900 ~ 960

STRUCTURE DIMENSIONS (mm)

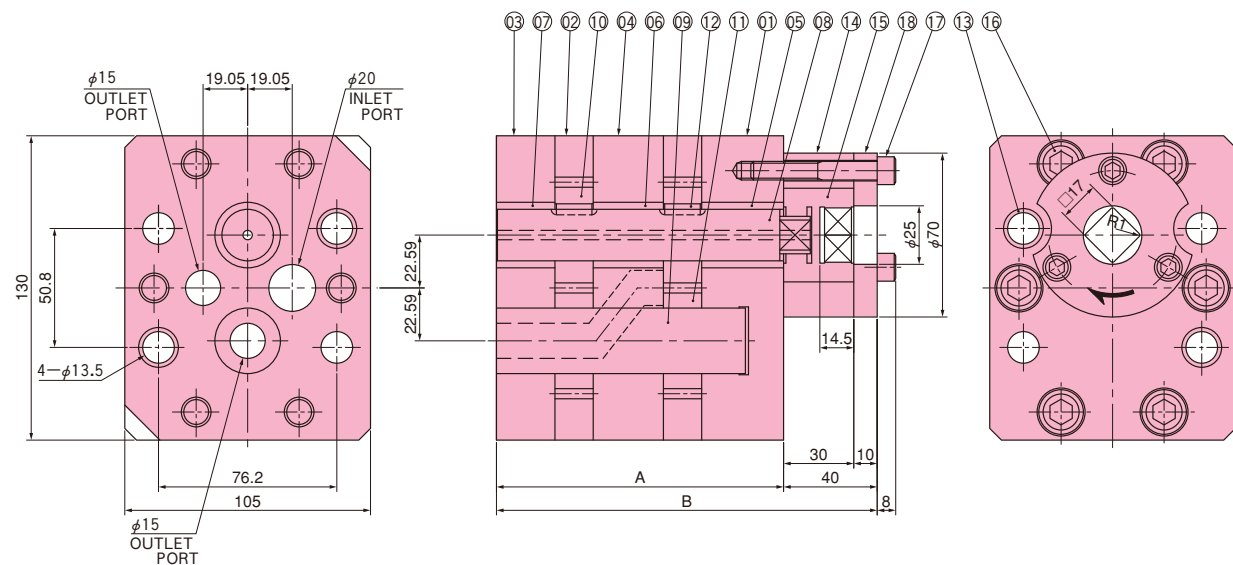

Model	Capacity (cm ³)	Diff. Press.		A	B	Mass (kg)
		MPa	kgf/cm ²			
KH2D-3-H	3×2	39.2	400	99.8	139.8	12.1
KH2D-5-H	5×2	39.2	400	106.3	146.3	12.8
KH2D-10-H	10×2	39.2	400	122.7	162.7	14.6
KH2D-15-H	15×2	29.4	300	139.3	179.3	16.4
KH2D-20-H	20×2	24.5	250	155.7	195.7	18.2

Parts List

Parts No.	Name	Q'ty/set
01	Front plate	1
02	Gear casing	2
03	Back plate	1
04	Middle plate	1
05	Bushing	1
06	Bushing	1
07	Bushing	1
08	Arbor	1
09	Stud	1
10	Driving gear	2
11	Driven gear	2
12	Key	2
13	Dowel	2
14	Hub	1
15	Coupler	1
16	Plate screw	6
17	Hub screw	3
18	Hub top	1

IAS SERIES

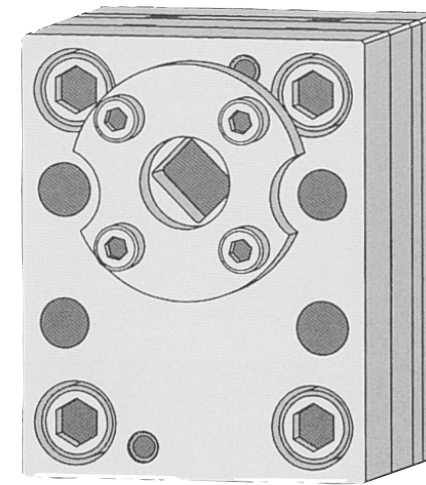

Main application : Melt spinning
 Number of ports : Inlet 1 ; Outlet 1
 Displacement / port : 5 ~ 20 cm³
 Inlet pressure : 0.5 MPa~19.6 MPa (5 kgf/cm² ~ 200 kgf/cm²)
 Outlet pressure : Max. 49.1 MPa (Max. 500 kgf/cm²)
 Differential pressure : Please refer to table as shown below.
 Temperature : Max. 350 °C
 Viscosity : Max. 400 Pa·s (Max. 4,000 Poise)
 Speed : 10 ~ 40 min⁻¹
 Standard material : High speed tool steel
 Torque list :

	Bolt size	Torque	
		N·m	kgf·cm
For plates	M14	137.3 ~ 147.2	1,400 ~ 1,500
For hub	M8	24.5 ~ 27.5	250 ~ 280
For mounting	M12	88.3 ~ 94.2	900 ~ 960

STRUCTURE DIMENSIONS (mm)

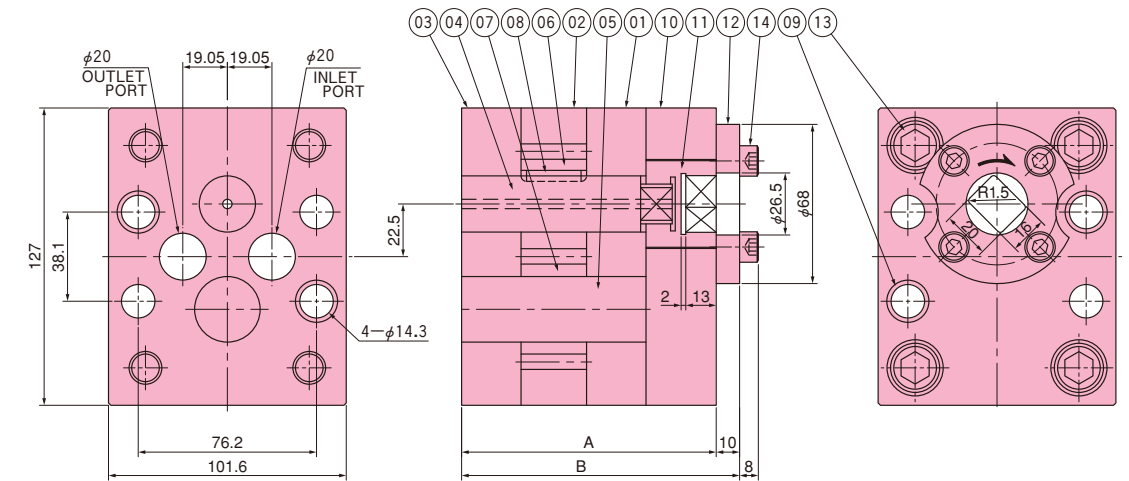

Model	Capacity (cm ³)	Diff. Press.		A	B	Mass (kg)
		MPa	kgf/cm ²			
IAS-5	5	39.2	400	87.8	97.8	9
IAS-7	7	39.2	400	92.3	102.3	9.5
IAS-10	10	39.2	400	97.2	107.2	10
IAS-15	15	39.2	400	105.4	115.4	10.8
IAS-20	20	39.2	400	113.6	123.6	11.7

Parts List

Parts No.	Name	Q'ty/set
01	Front plate	1
02	Gear casing	1
03	Back plate	1
04	Arbor	1
05	Stud	1
06	Driving gear	1
07	Driven gear	1
08	Key	1
09	Dowel	2
10	Hub	1
11	Coupler	1
12	Hub top	1
13	Plate screw	4
14	Hub screw	4

KH5 SERIES

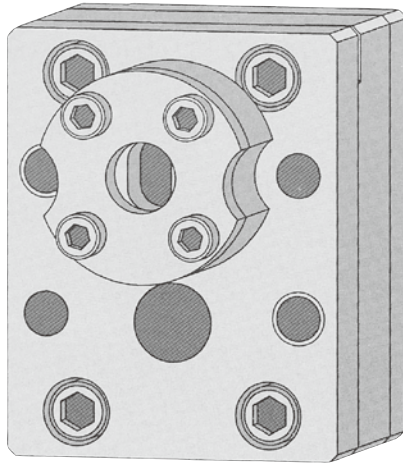

Main application : Melt spinning
 Number of ports : Inlet 1 ; Outlet 1
 Displacement / port : 30 ~ 60 cm³
 Inlet pressure : 0.5 MPa~9.8 MPa (5 kgf/cm² ~ 100 kgf/cm²)
 Outlet pressure : Max. 19.6 MPa (Max. 200 kgf/cm²)
 Differential pressure : Please refer to table as shown below.
 Temperature : Max. 350 °C
 Viscosity : Max. 400 Pa·s (Max. 4,000 Poise)
 Speed : 10 ~ 40 min⁻¹
 Standard material : Alloy tool steel
 Torque list :

	Bolt size	Torque	
		N·m	kgf·cm
For plates	M14	137.3 ~ 147.2	1,400 ~ 1,500
For hub	M8	24.5 ~ 27.5	250 ~ 280
For mounting	M14	137.3 ~ 147.2	1,400 ~ 1,500

STRUCTURE DIMENSIONS (mm)

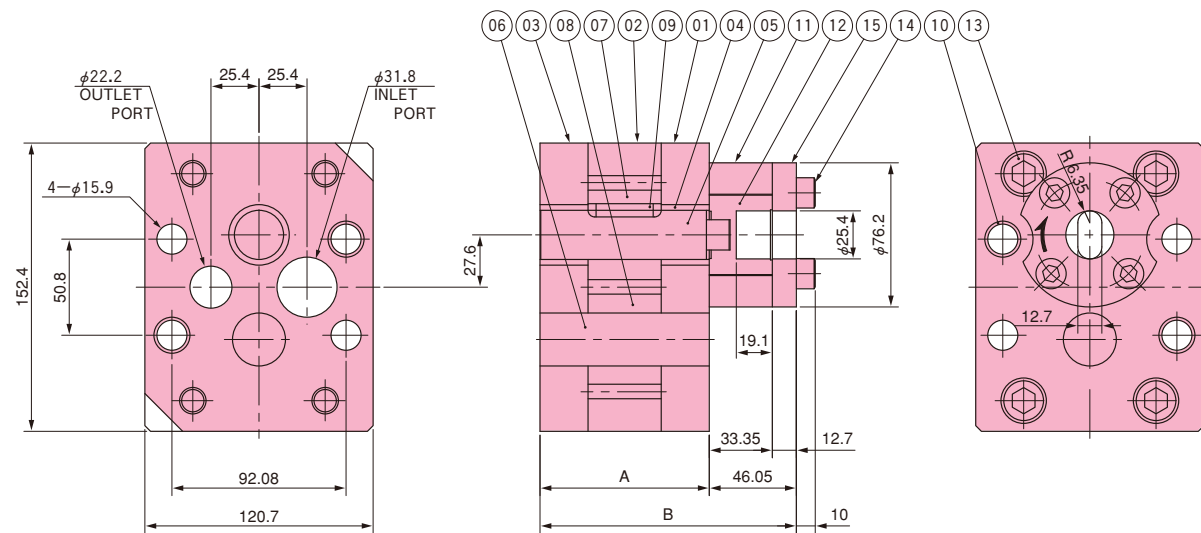

Model	Capacity (cm ³)	Diff. Press.		A	B	Mass (kg)
		MPa	kgf/cm ²			
KH5-30	30	14.7	150	74.2	120.2	12.5
KH5-40	40	14.7	150	82	128	13.6
KH5-50	50	14.7	150	89.5	135.5	14.7
KH5-60	60	14.7	150	97.6	143.6	15.9

Parts List

Parts No.	Name	Q'ty/set
01	Front plate	1
02	Gear casing	1
03	Back plate	1
04	Bushing	2
05	Arbor	1
06	Stud	1
07	Driving gear	1
08	Driven gear	1
09	Key	1
10	Dowel	2
11	Hub	1
12	Coupler	1
13	Hub top	1
14	Plate screw	4
15	Hub screw	4

KPS SERIES

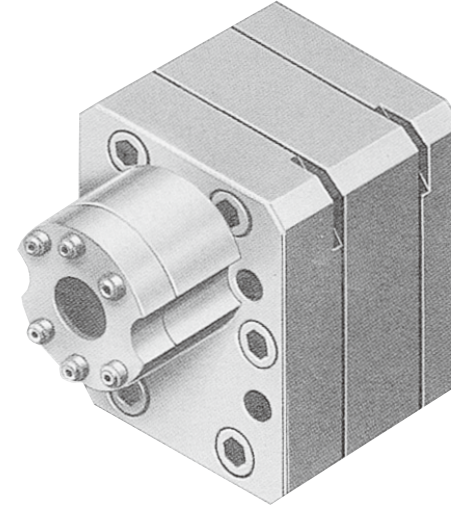

Main application : Melt spinning
 Number of ports : Inlet 1 ; Outlet 1
 Displacement / port : 30 ~ 100 cm³
 Inlet pressure : 0.5 MPa~19.6 MPa (5 kgf/cm² ~ 200 kgf/cm²)
 Outlet pressure : Max. 49.1 MPa (Max. 500 kgf/cm²)
 Differential pressure : Please refer to table as shown below.
 Temperature : Max. 350 °C
 Viscosity : Max. 400 Pa·s (Max. 4,000 Poise)
 Speed : 10 ~ 40 min⁻¹
 Standard material : Alloy tool steel
 Torque list :

	Bolt size	Torque	
		N·m	kgf·cm
For plates	M14	137.3 ~ 147.2	1,400 ~ 1,500
For hub	M8	24.5 ~ 27.5	250 ~ 280
For mounting	M16	225.6 ~ 245.3	2,300 ~ 2,500

STRUCTURE DIMENSIONS (mm)

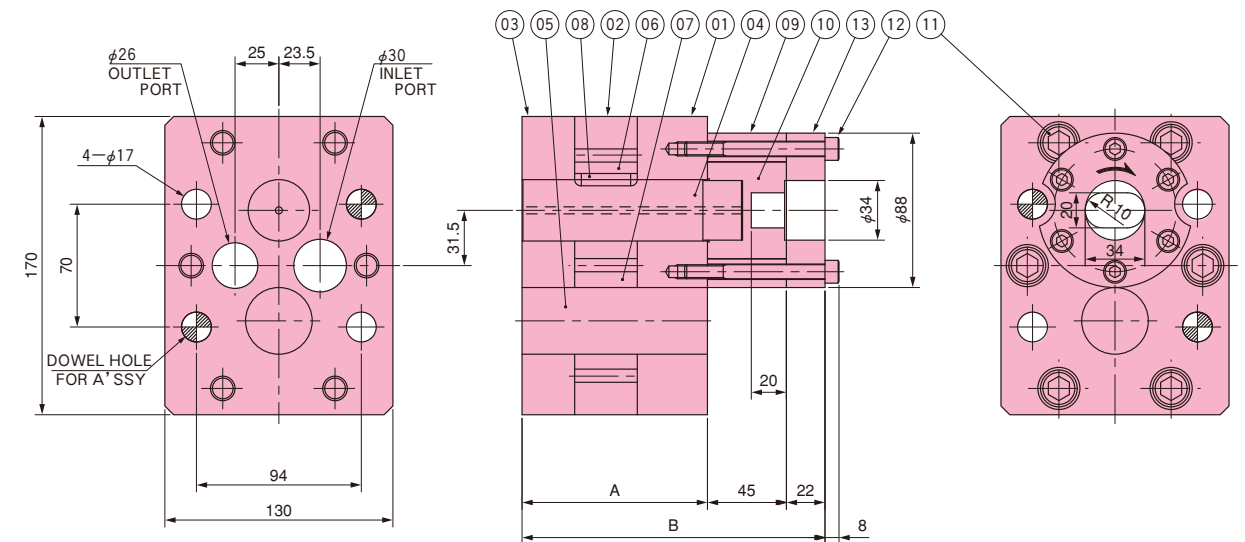

Model	Capacity (cm ³)	Diff. Press.		A	B	Mass (kg)
		MPa	kgf/cm ²			
KPS-30	30	39.2	400	91.4	158.4	19.3
KPS-40	40	39.2	400	98.5	165.5	20.7
KPS-50	50	39.2	400	105.6	172.6	21.9
KPS-60	60	29.4	300	112.8	179.8	23.2
KPS-70	70	29.4	300	119.8	186.8	24.4
KPS-100	100	29.4	300	141.9	208.9	28

Parts List

Parts No.	Name	Q'ty/set
01	Front plate	1
02	Gear casing	1
03	Back plate	1
04	Arbor	1
05	Stud	1
06	Driving gear	1
07	Driven gear	1
08	Key	1
09	Hub	1
10	Coupler	1
11	Plate screw	6
12	Hub screw	6
13	Hub top	1

KES SERIES

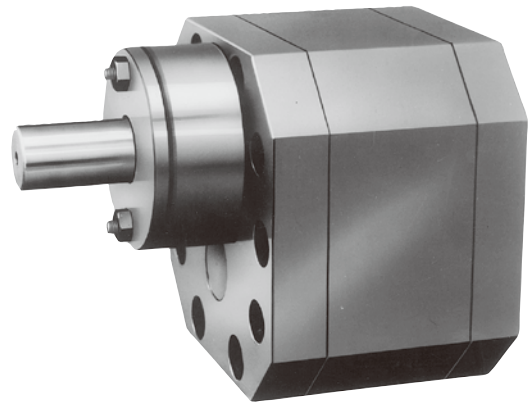

Main application : Melt spinning
 Number of ports : Inlet 1 ; Outlet 1
 Displacement / port : 80 ~ 200 cm³
 Inlet pressure : 0.5 MPa~9.8 MPa (5 kgf/cm² ~ 100 kgf/cm²)
 Outlet pressure : Max. 19.6 MPa (Max. 200 kgf/cm²)
 Differential pressure : Please refer to table as shown below.
 Temperature : Max. 350 °C
 Viscosity : Max. 400 Pa·s (Max. 4,000 Poise)
 Speed : 10 ~ 40 min⁻¹
 Standard material : Alloy tool steel
 Torque list :

	Bolt size	Torque	
		N·m	kgf·cm
For plates	M14	137.3 ~ 147.2	1,400 ~ 1,500
For hub	M10	49.1 ~ 53.9	500 ~ 550
For mounting	M14	137.3 ~ 147.2	1,400 ~ 1,500

STRUCTURE DIMENSIONS (mm)

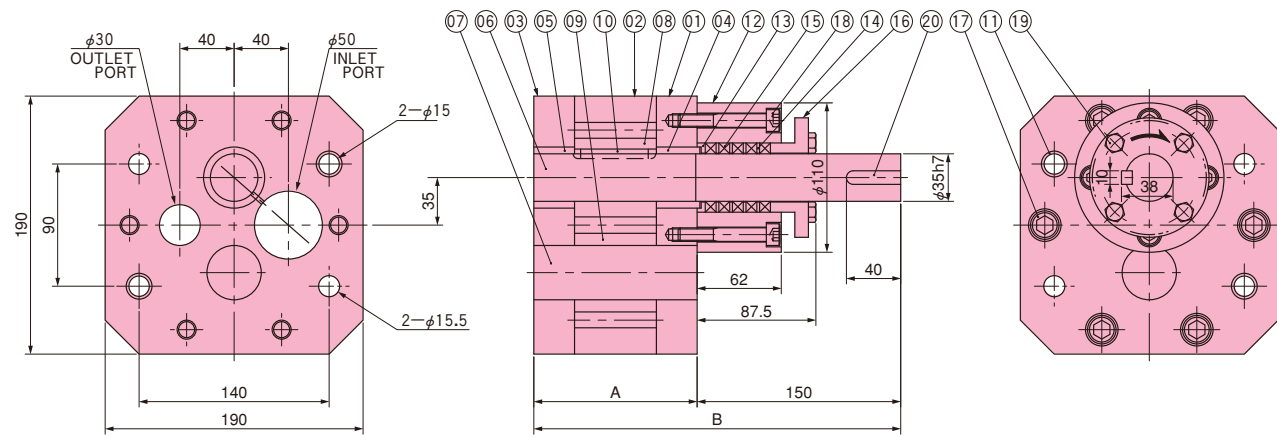

Model	Capacity (cm ³)	Diff. Press.		A	B	Mass (kg)
		MPa	kgf/cm ²			
KES-80	80	14.7	150	92.4	242.4	31.1
KES-100	100	14.7	150	100.5	250.5	33.4
KES-150	150	14.7	150	108.6	258.6	35.7
KES-200	200	9.8	100	141	291	45

Parts List

Parts No.	Name	Q'ty/set
01	Front plate	1
02	Gear casing	1
03	Back plate	1
04	Bushing	1
05	Bushing	1
06	Arbor	1
07	Stud	1
08	Driving gear	1
09	Driven gear	1
10	Key	1
11	Dowel	2
12	Hub	1
13	Spacer	1
14	Spacer	4
15	Gland packing	1
16	Retainer	1
17	Plate screw	6
18	Hub screw	4
19	Bolt	4
20	Key	1

KH8 SERIES

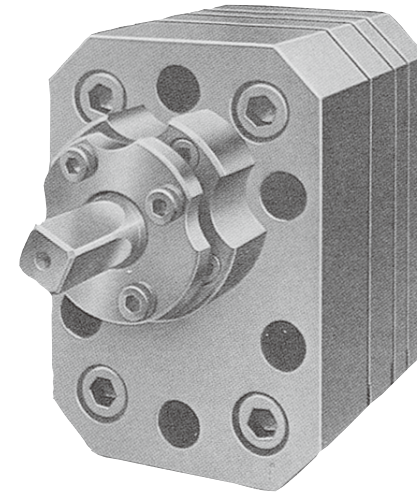

Main application : Melt spinning
 Number of ports : Inlet 1 ; Outlet 1
 Displacement / port : 5 ~ 20 cm³
 Inlet pressure : 1 MPa~19.6 MPa (10 kgf/cm² ~ 200 kgf/cm²)
 Outlet pressure : Max. 117.7 MPa (Max. 1,200 kgf/cm²)
 Differential pressure : Please refer to table as shown below.
 Temperature : Max. 350 °C
 Viscosity : Max. 1,000 Pa·s (Max. 10,000 Poise)
 Speed : 10 ~ 40 min⁻¹
 Standard material : High speed tool steel
 Torque list :

	Bolt size	Torque	
		N·m	kgf·cm
For plates	M18	264.9 ~ 294.3	2,700 ~ 3,000
For hub	M8	24.5 ~ 27.5	250 ~ 280
For mounting	M18	264.9 ~ 294.3	2,700 ~ 3,000

STRUCTURE DIMENSIONS (mm)

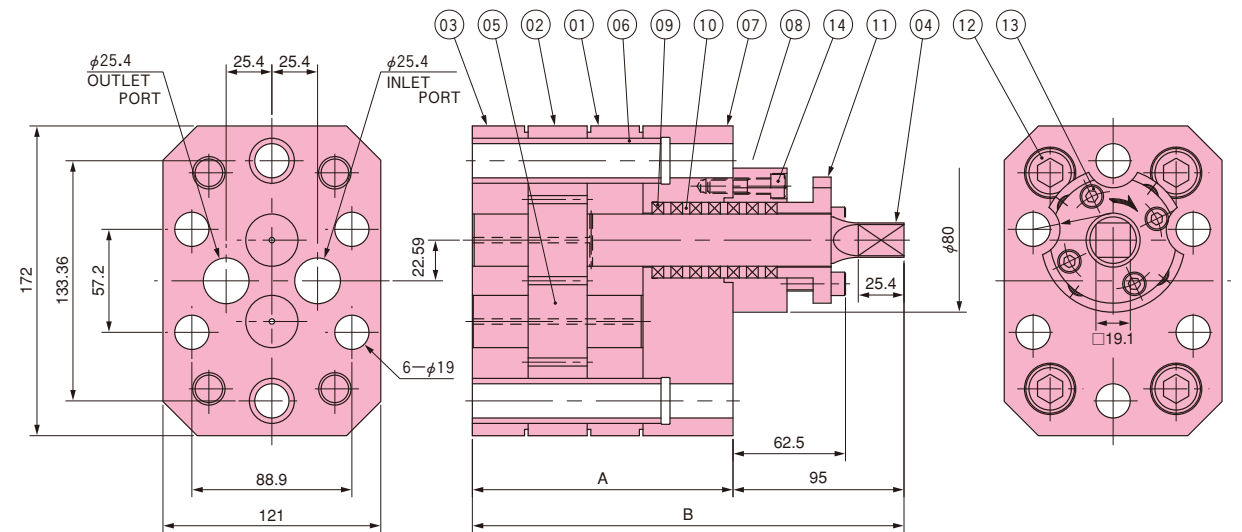

Model	Capacity (cm ³)	Diff. Press.		A	B	Mass (kg)
		MPa	kgf/cm ²			
KH8-5	5	98.1	1,000	120.2	215.2	19.3
KH8-10	10	98.1	1,000	128.4	223.4	21.1
KH8-15	15	88.3	900	136.6	231.6	22.5
KH8-20	20	78.5	800	144.8	239.8	23.9

Parts List

Parts No.	Name	Q'ty/set
01	Front plate	1
02	Gear casing	1
03	Back plate	1
04	Driving gear	1
05	Driven gear	1
06	Dowel	2
07	Hub	1
08	Seal housing	1
09	Gland packing	1
10	Spacer	6
11	Retainer	1
12	Plate screw	4
13	Screw	4
14	Hub screw	4

SCT SERIES

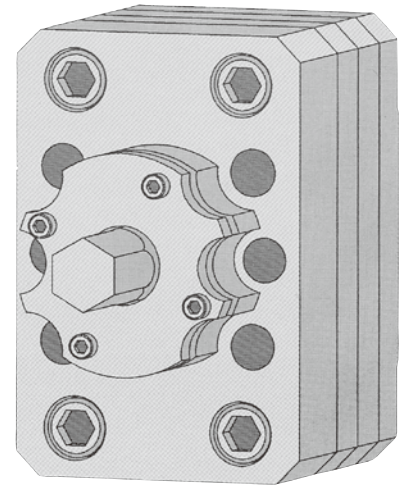

Main application : Melt spinning
 Number of ports : Inlet 2 ; Outlet 2
 Displacement / port : 10 ~ 40 cm³
 Inlet pressure : 1 MPa ~ 19.6 MPa (10 kgf/cm² ~ 200 kgf/cm²)
 Outlet pressure : Max. 58.9 MPa (Max. 600 kgf/cm²)
 Differential pressure : Please refer to table as shown below.
 Temperature : Max. 350 °C
 Viscosity : Max. 3,000 Pa · s (Max. 30,000 Poise)
 Speed : 10 ~ 40 min⁻¹
 Standard material : High speed tool steel
 Torque list :

	Bolt size	Torque	
		N · m	kgf · cm
For plates	M16	225.6~245.3	2,300~2,500
For hub	M6	9.8~ 11.8	100~ 120
For mounting	M16 / M18	225.6-245.3/264.9-294.3	2,300-2,500/2,700-3,000

STRUCTURE DIMENSIONS (mm)

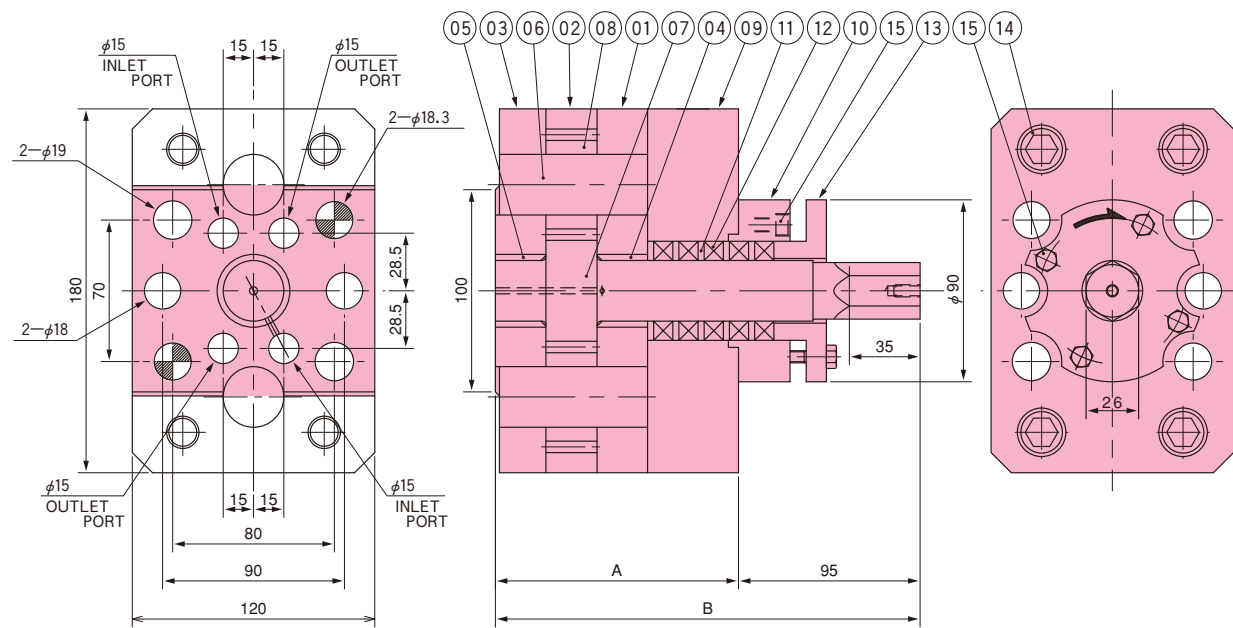

Model	Capacity (cm ³)	Diff. Press.		A	B	Mass (kg)
		MPa	kgf/cm ²			
SCT-10	10×2	49.1	500	105.1	200.1	18.1
SCT-15	15×2	49.1	500	110.1	205.1	19
SCT-20	20×2	49.1	500	115.2	210.2	19.9
SCT-25	25×2	49.1	500	120.2	215.2	20.7
SCT-30	30×2	39.2	400	125.2	220.2	21.6
SCT-40	40×2	39.2	400	135.3	230.3	23.3
SCT-50	50×2	39.8	400	145.5	240.5	25

Parts List

Parts No.	Name	Q'ty/set
01	Front plate	1
02	Gear casing	1
03	Back plate	1
04	Bushing	1
05	Bushing	1
06	Stud	2
07	Driving gear	1
08	Driven gear	2
09	Hub	1
10	Seal housing	1
11	Spacer	5
12	Gland packing	1
13	Retainer	1
14	Plate screw	4
15	Hub screw	8

KAP-1 SERIES

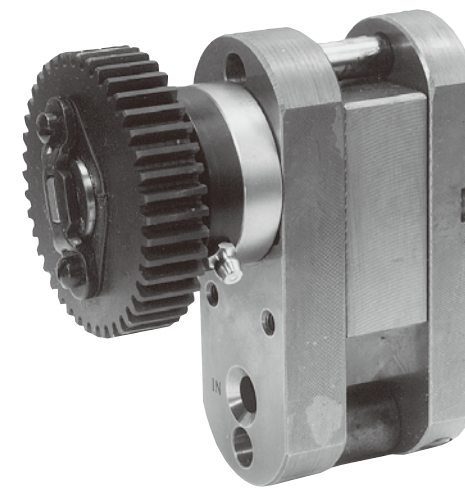

Main application : Wet & dry spinning
 Number of ports : Inlet 1 ; Outlet 1
 Displacement / port : 0.06 ~ 2.92 cm³
 Inlet pressure : 0.2 MPa ~ 2 MPa (2 kgf/cm² ~ 20 kgf/cm²)
 Outlet pressure : Max. 7.8 MPa (Max. 80 kgf/cm²)
 Differential pressure : Please refer to table as shown below.
 Temperature : Max. 120 °C
 Viscosity : Max. 100 Pa · s (Max. 1,000 Poise)
 Speed : 10 ~ 60 min⁻¹
 Standard material : Stainless steel
 Torque list :

	Bolt size	Torque	
		N · m	kgf · cm
For plates	#12-24UNC	6.9~7.8	70~80
For hub	#10-24UNC	4.4~4.9	45~50

STRUCTURE DIMENSIONS (mm)

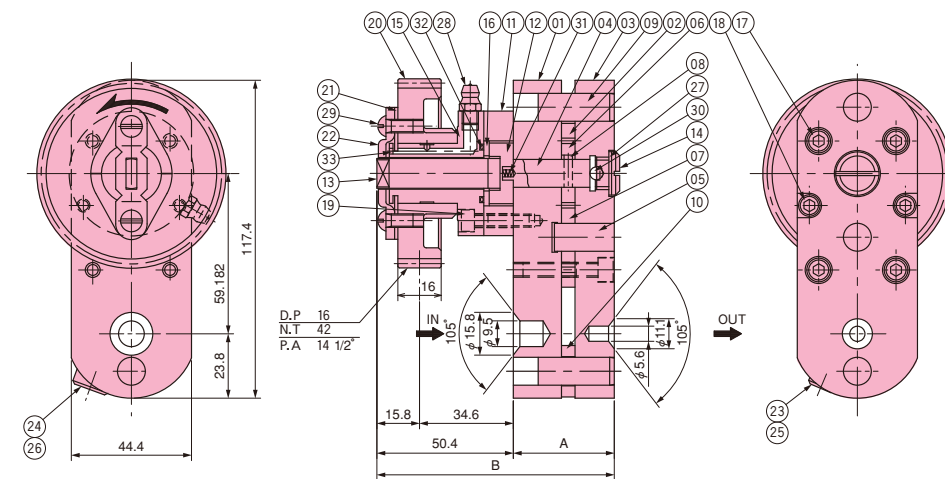

Model	Capacity (cm ³)	Diff. Press.		A	B	Mass (kg)
		MPa	kgf/cm ²			
KAP-1-0.06	0.06	6.9	70	34.4	84.9	1.9
KAP-1-0.15	0.15	6.9	70	34.7	85.2	1.9
KAP-1-0.297	0.297	6.9	70	36	86.5	1.9
KAP-1-0.584	0.584	6.9	70	37.3	87.8	1.9
KAP-1-1.168	1.168	6.9	70	42.3	92.8	2
KAP-1-1.752	1.752	6.9	70	47.3	97.8	2.1
KAP-1-2.92	2.92	6.9	70	57.2	107.7	2.3

Parts List

Parts No.	Name	Q'ty/set
01	Front plate	1
02	Gear casing	1
03	Back plate	1
04	Arbor	1
05	Stud	1
06	Driving gear	1
07	Driven gear	1
08	Key	1
09	Dowel	2
10	Spacer	1
11	Hub	1
12	Coupler	1
13	Outer shaft	1
14	Plug	1
15	Bearing outer	1
16	Seal plate	1
17	Plate screw	4
18	Plate screw	2
19	Hub screw	3
20	Outer gear	1
21	Retainer plate	2
22	Retainer yoke	1
23	Plug	1
24	Plug	1
25	Gasket	1
26	Gasket	1
27	Gasket	1
28	Grease nipple	1
29	Screw	1
30	Ball	1
31	Spring	1
32	O-ring	1
33	Pin	1

KVP-1 SERIES

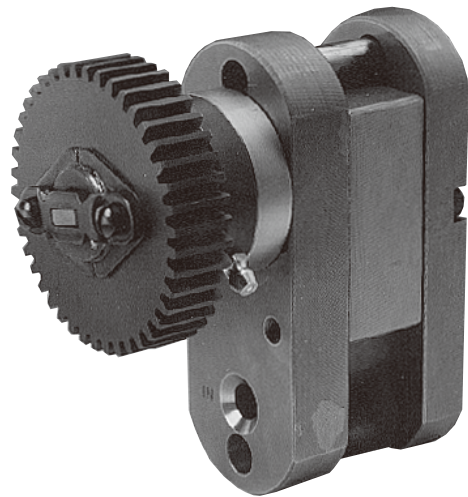

Main application : Wet & dry spinning
 Number of ports : Inlet 1 ; Outlet 1
 Displacement / port : 0.297 ~ 2.92 cm³
 Inlet pressure : 0.2 MPa ~ 1 MPa (2 kgf/cm² ~ 10 kgf/cm²)
 Outlet pressure : Max. 2.9 MPa (Max. 30 kgf/cm²)
 Differential pressure : Please refer to table as shown below.
 Temperature : Max. 120 °C
 Viscosity : Max. 100 Pa·s (Max. 1,000 Poise)
 Speed : 10 ~ 60 min⁻¹
 Standard material : Stainless steel

Torque list :

	Bolt size	Torque	
		N·m	kgf·cm
For plates	#12-24UNC	6.9~7.8	70~80
For hub	#10-24UNC	4.4~4.9	45~50

STRUCTURE DIMENSIONS (mm)

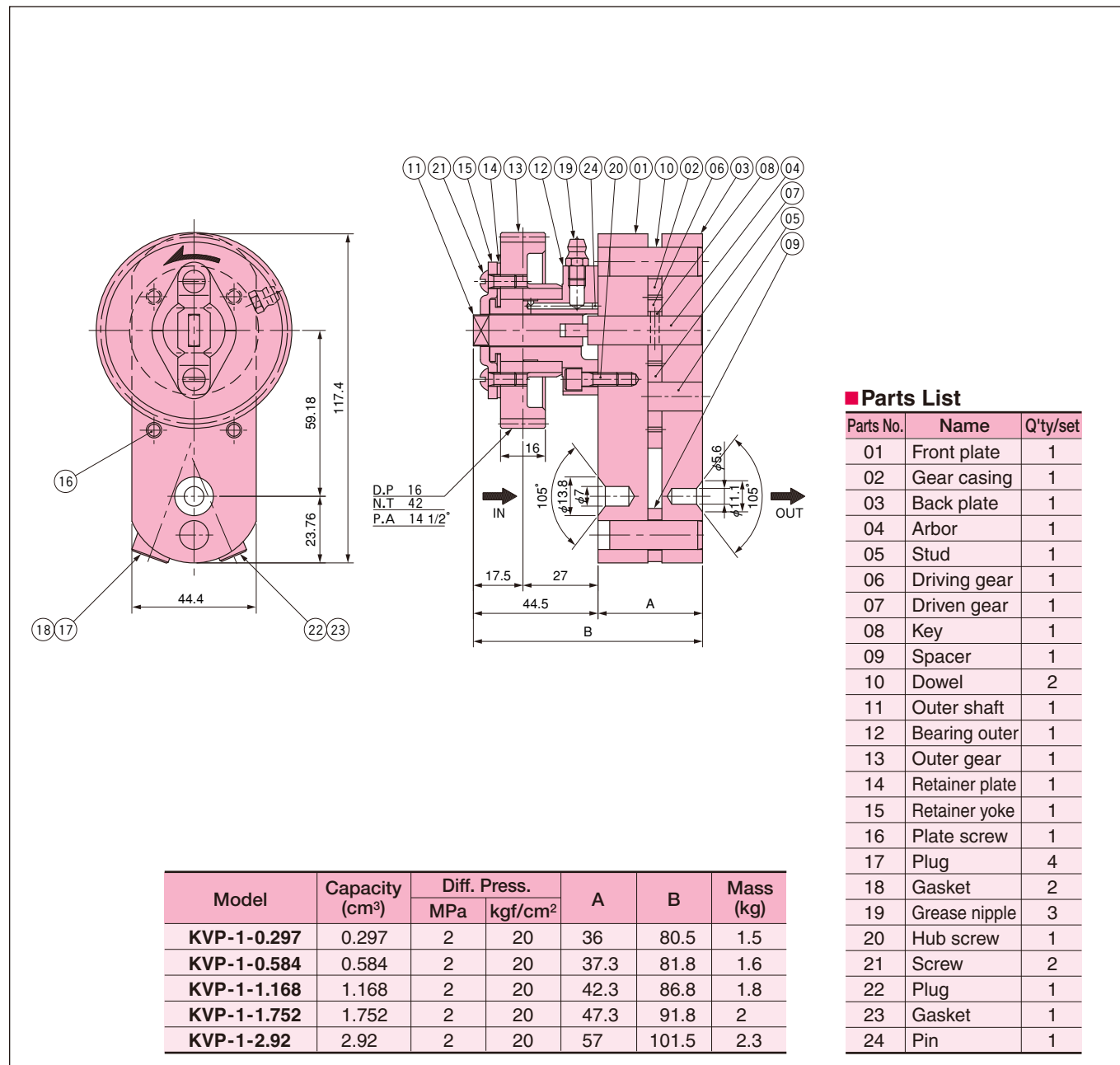

KA1D SERIES

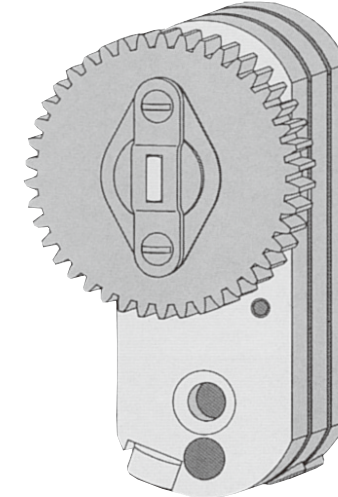

Main application : Wet & dry spinning
 Number of ports : Inlet 1 ; Outlet 2
 Displacement / port : 0.297 ~ 1.168 cm³
 Inlet pressure : 0.2 MPa ~ 2 MPa (2 kgf/cm² ~ 20 kgf/cm²)
 Outlet pressure : Max. 7.8 MPa (Max. 80 kgf/cm²)
 Differential pressure : Please refer to table as shown below.
 Temperature : Max. 120 °C
 Viscosity : Max. 100 Pa·s (Max. 1,000 Poise)
 Speed : 10 ~ 60 min⁻¹
 Standard material : Stainless steel

Torque list :

	Bolt size	Torque	
		N·m	kgf·cm
For plates	#12-24UNC	6.9~7.8	70~80
For hub	#10-24UNC	4.4~4.9	45~50

STRUCTURE DIMENSIONS (mm)

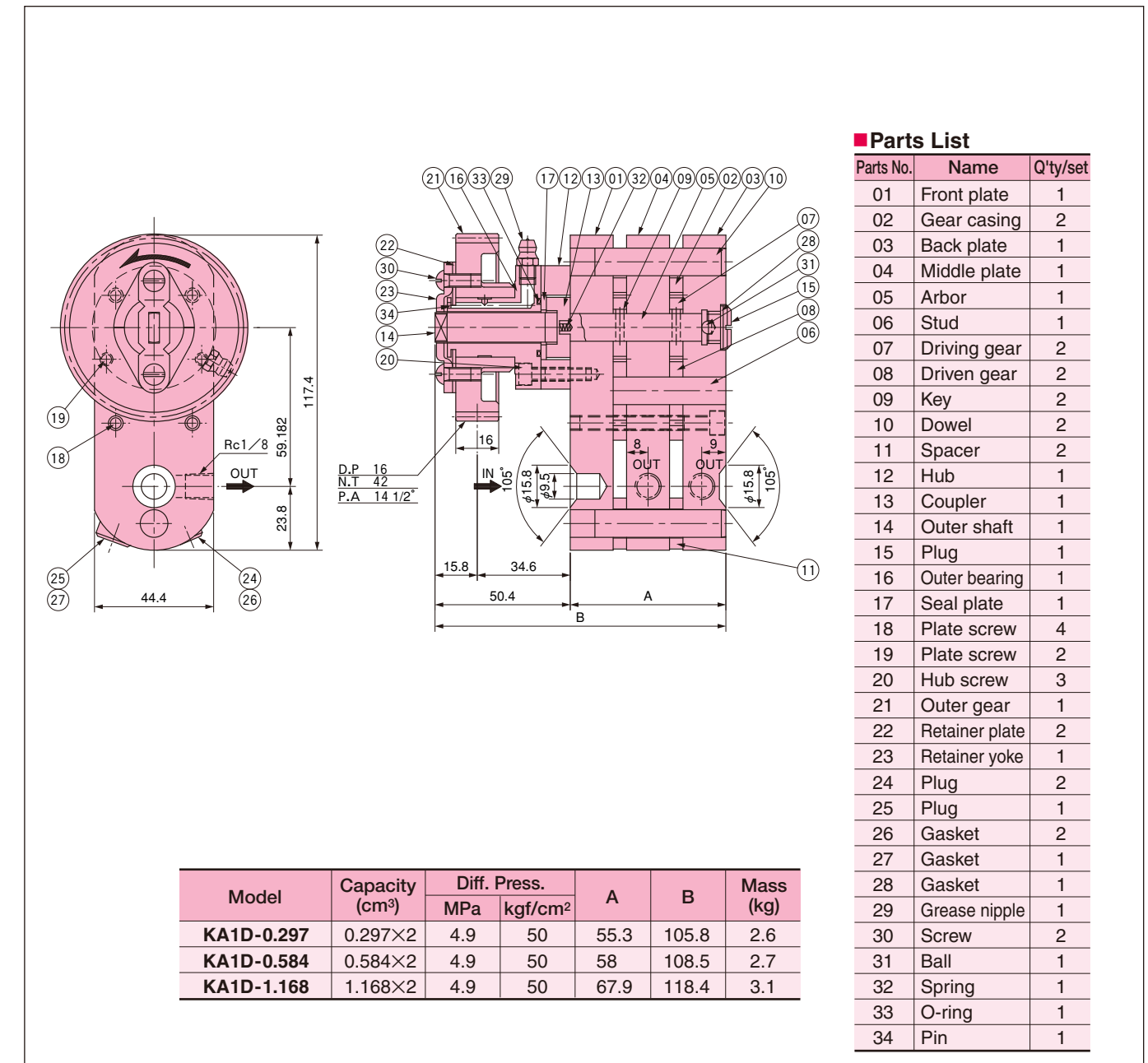

KA3 SERIES

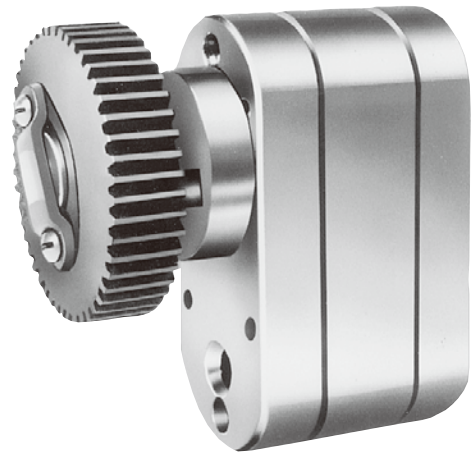

Main application : Wet & dry spinning
 Number of ports : Inlet 1 ; Outlet 1
 Displacement / port : 3 ~ 7.6 cm³
 Inlet pressure : 0.2 MPa ~ 2 MPa (2 kgf/cm² ~ 20 kgf/cm²)
 Outlet pressure : Max. 7.8 MPa (Max. 80 kgf/cm²)
 Differential pressure : Please refer to table as shown below.
 Temperature : Max. 120 °C
 Viscosity : Max. 100 Pa·s (Max. 1,000 Poise)
 Speed : 10 ~ 60 min⁻¹
 Standard material : Stainless steel

Torque list :

	Bolt size	Torque	
		N·m	kgf·cm
For plates	1/4"-24UNC	9.8~ 11.8	100~120
For hub	#12-24UNC	6.9~ 7.8	70~ 80

STRUCTURE DIMENSIONS (mm)

DP=16
Z=48
P.A=14 1/2°

IN OUT

40°

59.182

123

23.8

54

22(24)

25(23)

19

105°

35

52.5

A

B

Parts List

Parts No.	Name	Q'ty/set
01	Front plate	1
02	Gear casing	1
03	Back plate	1
04	Arbor	1
05	Stud	1
06	Driving gear	1
07	Driven gear	1
08	Key	1
09	Dowel	2
10	O-ring	1
11	Hub	1
12	Coupler	1
13	Outer shaft	1
14	Plug	1
15	Bearing outer	1
16	Sear plate	1
17	Plate screw	6
18	Hub bolt	3
19	Outer gear	1
20	Retainer plate	2
21	Retainer yoke	1
22	Plug	1
23	Plug	1
24	Gasket	1
25	Gasket	1
26	Grease nipple	1
27	Screw	2
28	Ball	1
29	Gasket	1
30	Spring	1
31	Pin	1

Model	Capacity (cm ³)	Diff. Press.		A	B	Mass (kg)
		MPa	kgf/cm ²			
KA3-3	3	6.9	70	47.6	99.9	3.2
KA3-5	5	6.9	70	55.3	107.6	3.6
KA3-7.6	7.6	6.9	70	65.4	117.7	4.1

KA4 SERIES

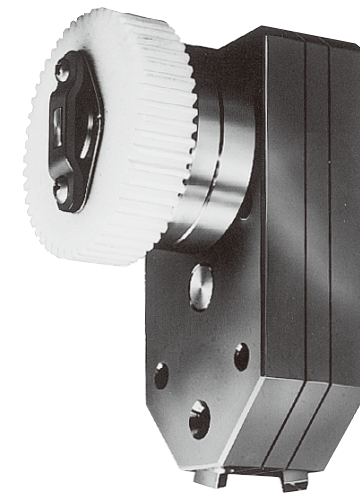

Main application : Wet & dry spinning
 Number of ports : Inlet 1 ; Outlet 1
 Displacement / port : 15 ~ 30 cm³
 Inlet pressure : 0.2 MPa ~ 1 MPa (2 kgf/cm² ~ 10 kgf/cm²)
 Outlet pressure : Max. 2.9 MPa (Max. 30 kgf/cm²)
 Differential pressure : Please refer to table as shown below.
 Temperature : Max. 120 °C
 Viscosity : Max. 100 Pa·s (Max. 1,000 Poise)
 Speed : 10 ~ 60 min⁻¹
 Standard material : Stainless steel

Torque list :

	Bolt size	Torque	
		N·m	kgf·cm
For plates	M8	24.5~ 27.5	250~280
For hub	M6	9.8~ 11.8	100~120

STRUCTURE DIMENSIONS (mm)

M=1.5
Z=50
P.A=20°

IN OUT

72

195

85

6

15

19

90°

17.5

35

A

B

Parts List

Parts No.	Name	Q'ty/set
01	Front plate	1
02	Gear casing	1
03	Back plate	1
04	Bushing	1
05	Bushing	1
06	Arbor	1
07	Stud	1
08	Driving gear	1
09	Driven gear	1
10	Key	1
11	Hub	1
12	Coupler	1
13	Seal plate	1
14	Plate screw	6
15	Gasket	1
16	Ball	1
17	Plug	1
18	Plug	2
19	Gasket	2
20	Outer gear	1
21	Bearing outer	1
22	Hub screw	3
23	Retainer yoke	1
24	Screw	2
25	Retainer plate	2
26	Outer shaft	1
27	O-ring	1
28	Spring	1

Model	Capacity (cm ³)	Diff. Press.		A	B	Mass (kg)
		MPa	kgf/cm ²			
KA4-15	15	2	20	47	99	4.5
KA4-30	30	2	20	64	116	5.8

KV4/KV5/KV6 SERIES

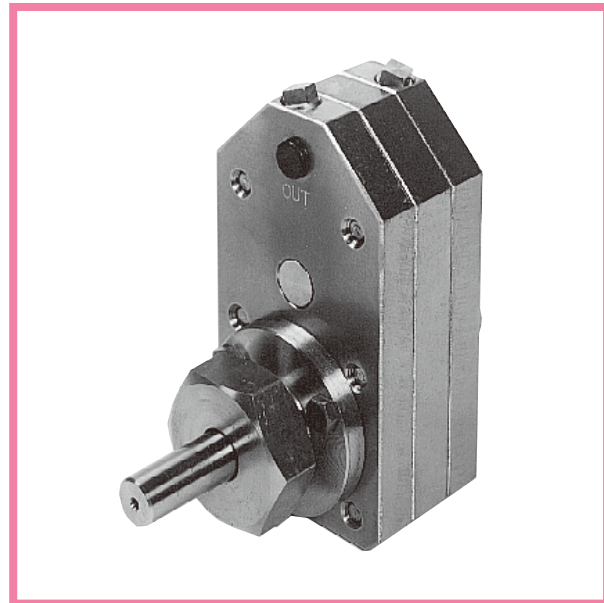

Main application : Wet & dry spinning
 Number of ports : Inlet 1 ; Outlet 1
 Displacement / port : 2 ~ 100 cm³
 Inlet pressure : 0.2 MPa ~ 1 MPa (2 kgf/cm² ~ 10 kgf/cm²)
 Outlet pressure : Max. 2.9 MPa (Max. 30 kgf/cm²)
 Differential pressure : Please refer to table as shown below.
 Temperature : Max. 120 °C
 Viscosity : Max. 100 Pa·s (Max. 1,000 Poise)
 Speed : 10 ~ 60 min⁻¹
 Standard material : Stainless steel

STRUCTURE DIMENSIONS (mm)

Torque list :

	Bolt size	Torque	
		N·m	kgf·cm
For plates	M8	24.5 ~ 27.5	250 ~ 280
For hub	M6	9.8 ~ 11.8	100 ~ 120

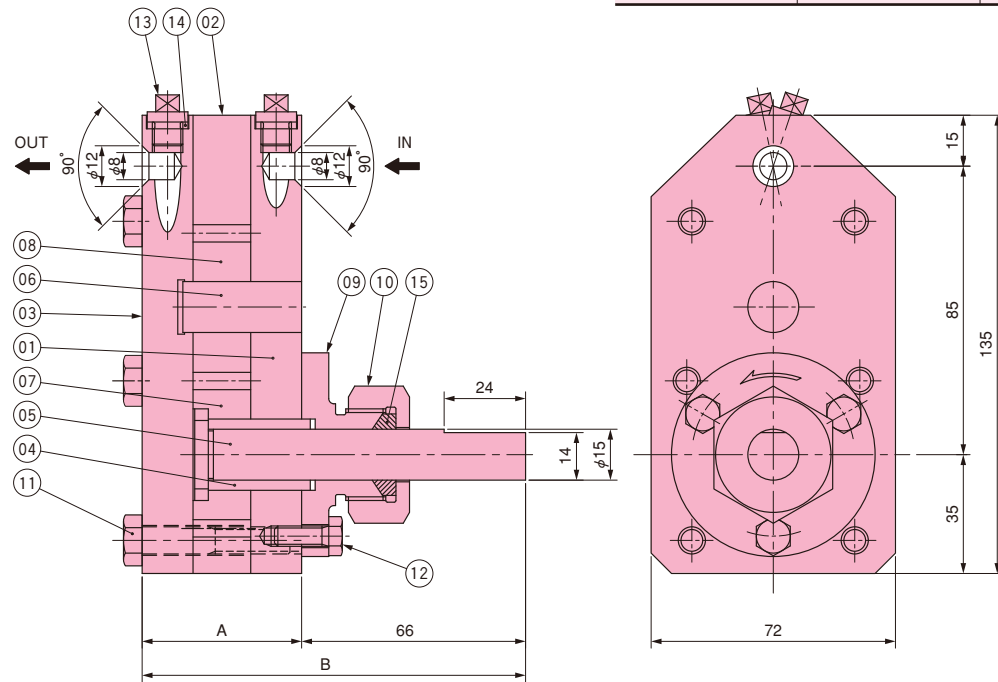

Parts List

Parts No.	Name	Q'ty/set
01	Front plate	1
02	Gear casing	1
03	Back plate	1
04	Bushing	1
05	Arbor	1
06	Stud	1
07	Driving gear	1
08	Driven gear	1
09	Bearing outer	1
10	Cap nut	1
11	Plate screw	6
12	Hub screw	3
13	Plug	2
14	Gasket	2
15	Gland packing	1

Model	Capacity (cm ³)	Diff. Press.		A	B	Mass (kg)
		MPa	kgf/cm ²			
KV4-2	2	2	20	39.8	105.8	3.1
KV4-4	4	2	20	42	108	3.3
KV4-6	6	2	20	38.7	104.7	3
KV4-8	8	2	20	42	108	3.3
KV4-12	12	2	20	47.4	113.4	3.7
KV4-15	15	2	20	47	113	3.7
KV4-20	20	2	20	52.7	118.7	4.1
KV4-30	30	2	20	64	130	5

Torque list :

	Bolt size	Torque	
		N·m	kgf·cm
For plates	M12	61.8 ~ 65.7	630 ~ 670
For hub	M10	34.3 ~ 38.3	350 ~ 390

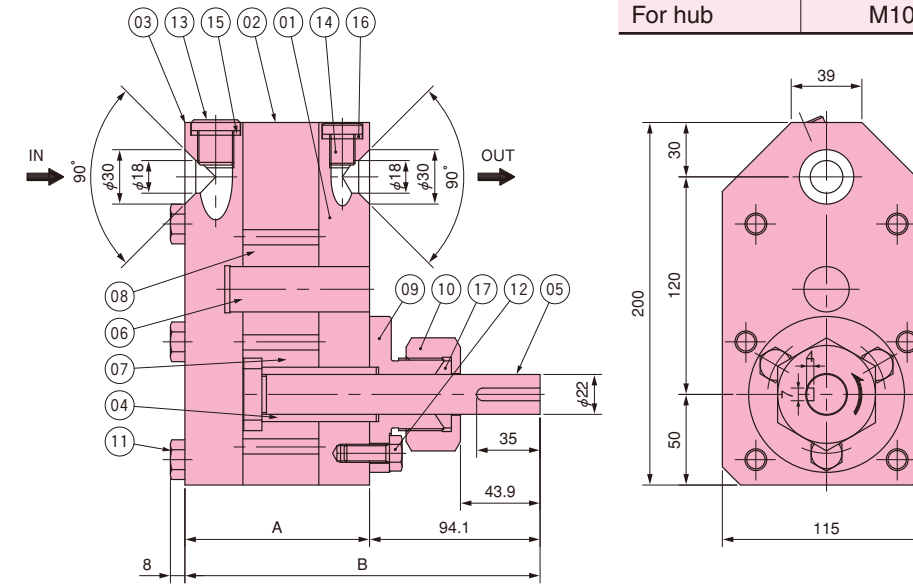

Model	Capacity (cm ³)	Diff. Press.		A	B	Mass (kg)
		MPa	kgf/cm ²			
KV5-60	60	2	20	101.9	196	18.8
KV5-100	100	2	20	129.8	223.9	23.9

Parts List

Parts No.	Name	Q'ty/set
01	Front plate	1
02	Gear casing	1
03	Back plate	1
04	Bushing	1
05	Arbor	1
06	Stud	1
07	Driving gear	1
08	Driven gear	1
09	Bearing outer	1
10	Cap nut	1
11	Plate screw	6
12	Hub screw	3
13	Plug	1
14	Plug	1
15	Gasket	1
16	Gasket	1
17	Gland packing	1

Torque list :

	Bolt size	Torque	
		N·m	kgf·cm
For plates	M10	49.1 ~ 53.9	500 ~ 550
For hub	M8	24.5 ~ 27.5	250 ~ 280

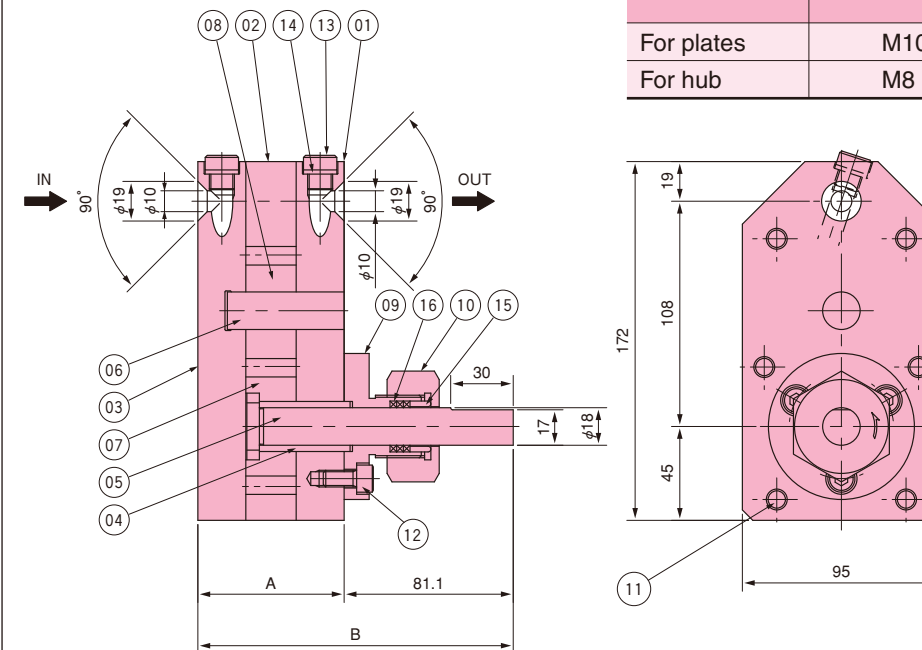

Model	Capacity (cm ³)	Diff. Press.		A	B	Mass (kg)
		MPa	kgf/cm ²			
KV6-15	15	2	20	56.4	137.5	7.3
KV6-20	20	2	20	64.4	145.5	8.3
KV6-25	25	2	20	68.9	150	8.9
KV6-30	30	2	20	66.7	147.8	8.6
KV6-40	40	2	20	73.6	154.7	9.5

Parts List

Parts No.	Name	Q'ty/set
01	Front plate	1
02	Gear casing	1
03	Back plate	1
04	Bushing	1
05	Arbor	1
06	Stud	1
07	Driving gear	1
08	Driven gear	1
09	Bearing outer	1
10	Cap nut	1
11	Plate screw	6
12	Hub screw	3
13	Plug	2
14	Gasket	2
15	Retainer	1
16	Gland packing	1

KAP-2 SERIES

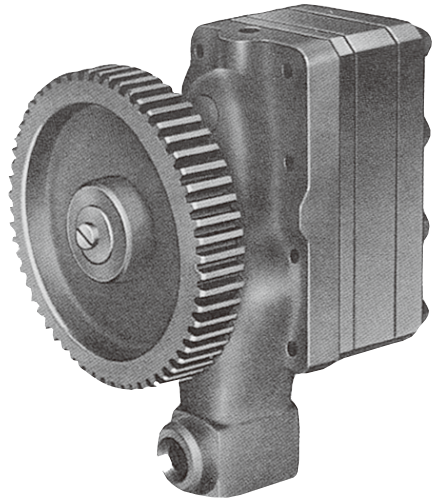

Main application : Wet & dry spinning
 Number of ports : Inlet 1 ; Outlet 1
 Displacement / port : 11.1 ~ 50 cm³
 Inlet pressure : 0.2 MPa ~ 2 MPa (2 kgf/cm² ~ 20 kgf/cm²)
 Outlet pressure : Max. 7.8 MPa (Max. 80 kgf/cm²)
 Differential pressure : Please refer to table as shown below.
 Temperature : Max. 120 °C
 Viscosity : Max. 100 Pa·s (Max. 1,000 Poise)
 Speed : 10 ~ 60 min⁻¹
 Standard material : Stainless steel

Torque list :

	Bolt size	Torque	
		N·m	kgf·cm
For plates	5/16-18UNC	21.6~24.5	220~250
For hub	#10-24UNC	4.4~4.9	45~50

STRUCTURE DIMENSIONS (mm)

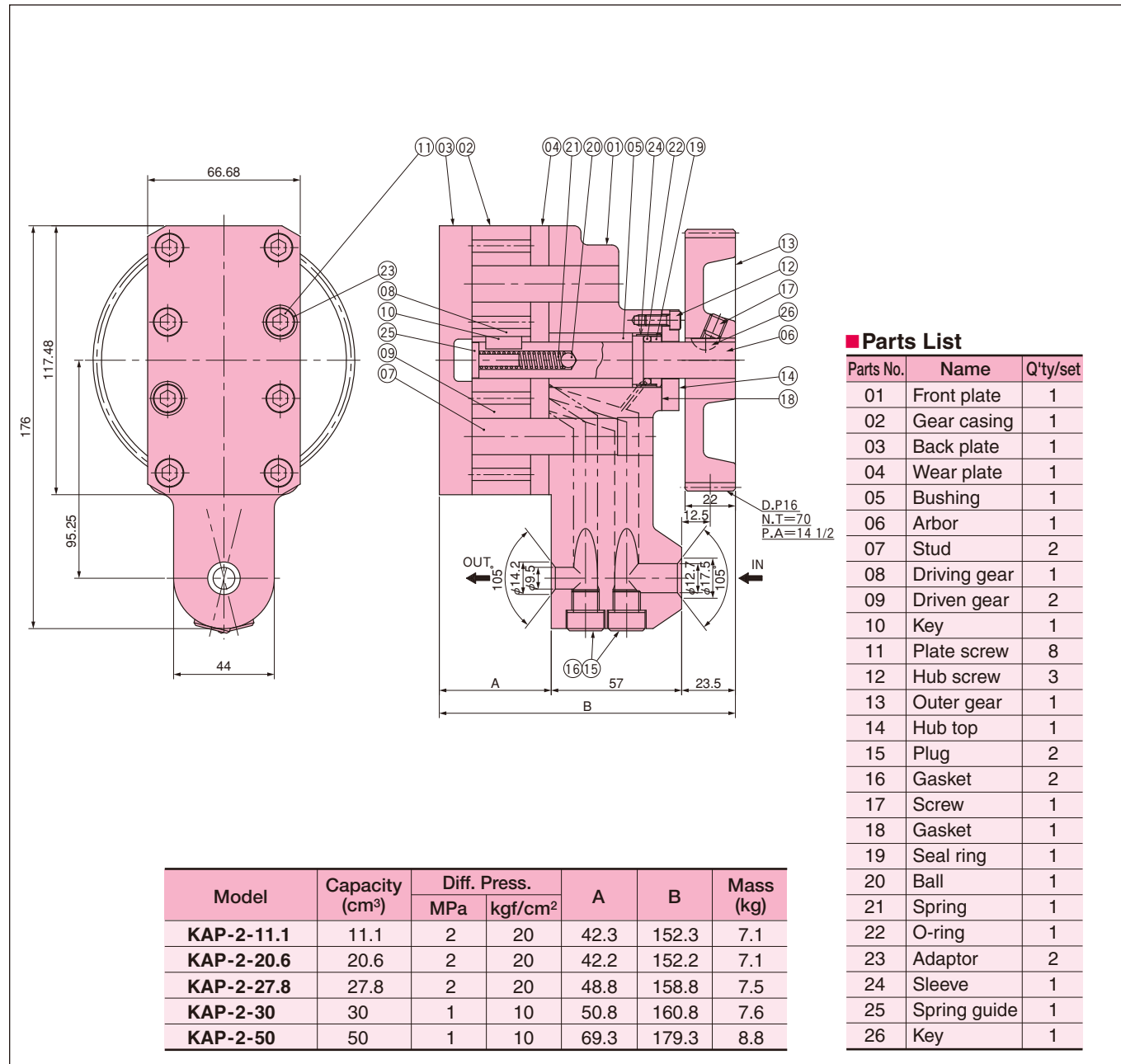

KVP-2 SERIES

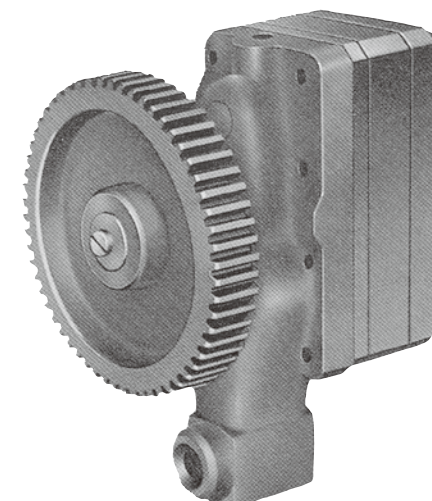

Main application : Wet & dry spinning
 Number of ports : Inlet 1 ; Outlet 1
 Displacement / port : 11.1 ~ 50 cm³
 Inlet pressure : 0.1 MPa ~ 1 MPa (1 kgf/cm² ~ 10 kgf/cm²)
 Outlet pressure : Max. 2.9 MPa (Max. 30 kgf/cm²)
 Differential pressure : Please refer to table as shown below.
 Temperature : Max. 120 °C
 Viscosity : Max. 100 Pa·s (Max. 1,000 Poise)
 Speed : 10 ~ 60 min⁻¹
 Standard material : Stainless steel

Torque list :

	Bolt size	Torque	
		N·m	kgf·cm
For plates	5/16-18UNC	21.6~24.5	220~250

STRUCTURE DIMENSIONS (mm)

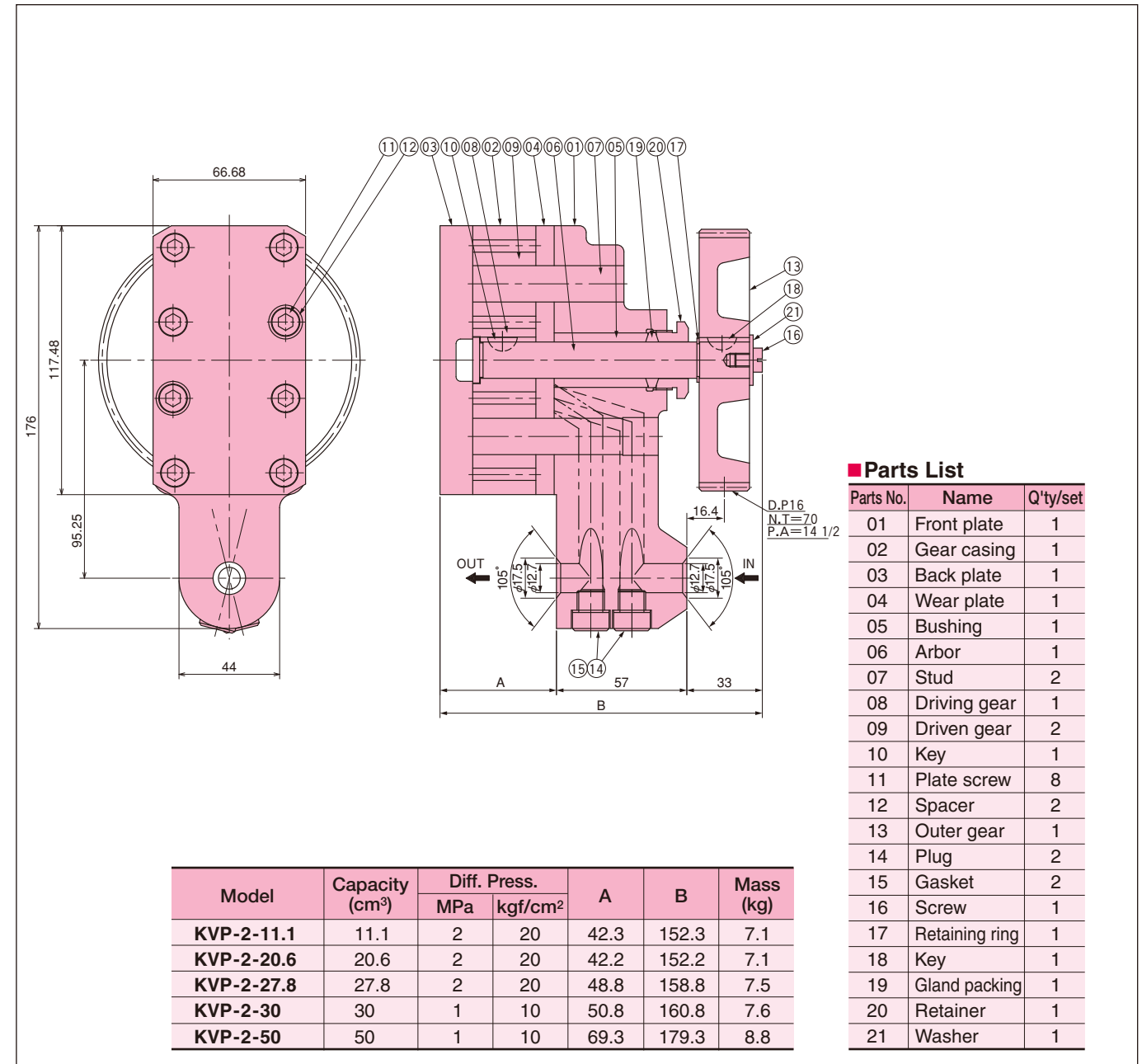

KWTD/KWT1D/KWT2D/

Main application : Spin-finish
 Number of ports : Inlet 1 ;
 Outlet

Model	KWTD	KWT1D	KWT2D	KWT3D	KWT4D
Number of ports	4	6	8	12	16

Displacement / port : 0.02 ~ 0.3 cm³
 Inlet pressure : 0 MPa~0.05 MPa (0 kgf/cm² ~ 0.5 kgf/cm²)
 Outlet pressure : Max. 0.05 MPa (Max. 0.5 kgf/cm²)
 Differential pressure : Max. 0.02 MPa (Max. 0.2 kgf/cm²)
 Temperature : Max. 50 °C
 Viscosity : Max. 50 mPa·s (Max. 50 C. Poise)
 Speed : 10 ~ 60 min⁻¹
 Standard material : Stainless steel
 Torque list :

	Bolt size	Torque	
		N·m	kgf·cm
For plates	M5	4.9~5.9	50~60
For hub	M5	4.9~5.9	50~60

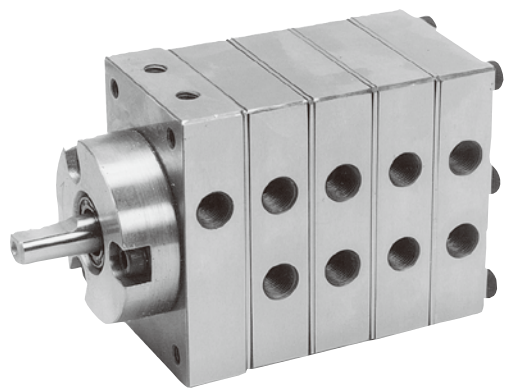

STRUCTURE DIMENSIONS (mm)

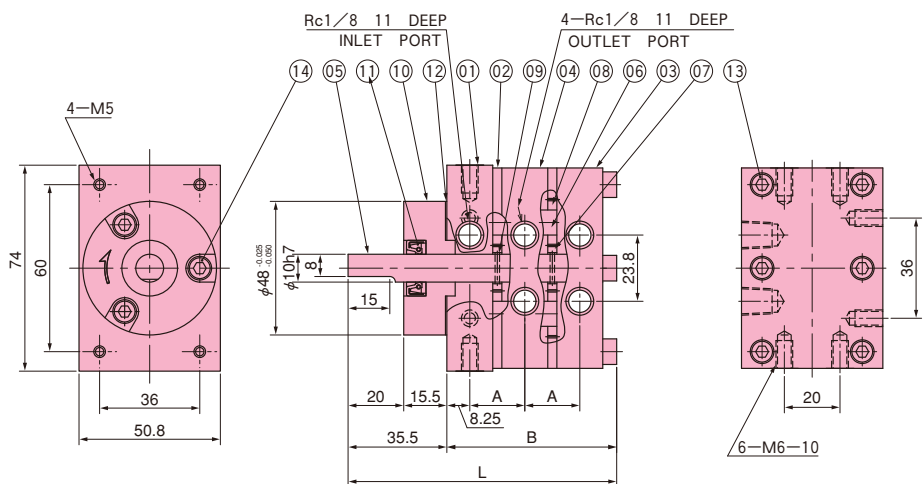

Parts List

Parts No.	Name	Q'ty/set
01	Front plate	1
02	Gear casing	2
03	Back plate	1
04	Middle plate	1
05	Arbor	1
06	Stud	2
07	Driving gear	2
08	Driven gear	4
09	Key	2
10	Seal housing	1
11	Oil seal	1
12	Gasket	1
13	Plate screw	6
14	Hub screw	3

Model	Capacity (cm ³)	A	B	L	Mass (kg)	Model	Capacity (cm ³)	A	B	L	Mass (kg)
KWTD-0.02	0.02×4	17.8	57.1	92.6	1.5	KWTD-0.15	0.15×4	19.8	61.1	96.6	1.7
KWTD-0.06	0.06×4	17.8	57.1	92.6	1.5	KWTD-0.2	0.2×4	20.9	63.3	98.8	1.7
KWTD-0.1	0.1×4	18.7	58.9	94.4	1.6	KWTD-0.3	0.3×4	20.2	61.9	97.4	1.7

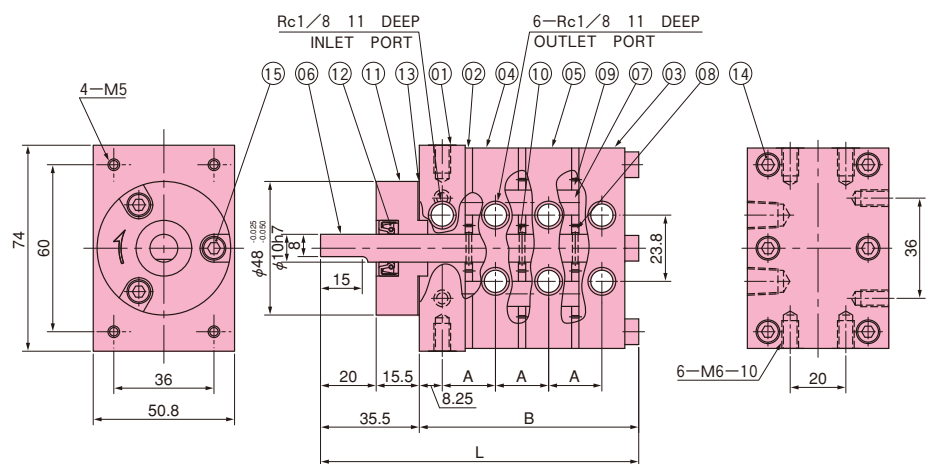

Parts List

Parts No.	Name	Q'ty/set
01	Front plate	1
02	Gear casing	3
03	Back plate	1
04	Middle plate	1
05	Middle plate	1
06	Arbor	1
07	Stud	2
08	Driving gear	3
09	Driven gear	6
10	Key	3
11	Seal housing	1
12	Oil seal	1
13	Gasket	1
14	Plate screw	6
15	Hub screw	3

Model	Capacity (cm ³)	A	B	L	Mass (kg)	Model	Capacity (cm ³)	A	B	L	Mass (kg)
KWT1D-0.02	0.02×6	17.8	74.9	110.4	2	KWT1D-0.15	0.15×6	19.8	80.9	116.4	2.2
KWT1D-0.06	0.06×6	17.8	74.9	110.4	2	KWT1D-0.2	0.2×6	20.9	84.2	119.7	2.3
KWT1D-0.1	0.1×6	18.7	77.6	113.1	2.1	KWT1D-0.3	0.3×6	20.2	82.1	117.6	2.3

KWT3D/KWT4D SERIES

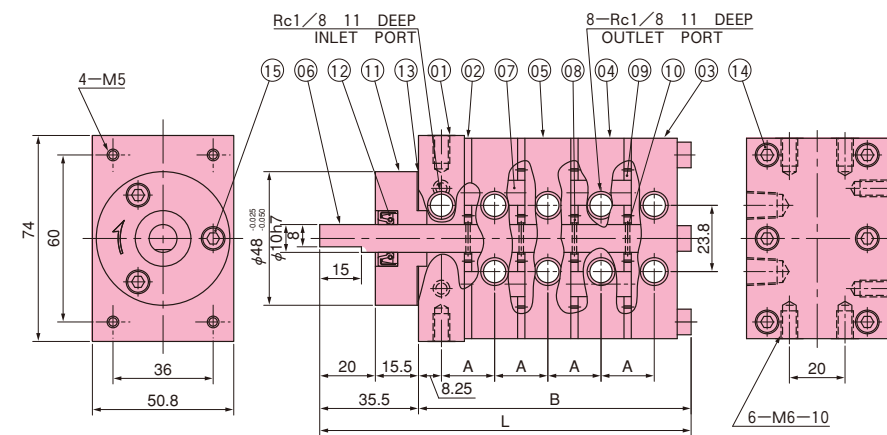

Model	Capacity (cm ³)	A	B	L	Mass (kg)	Model	Capacity (cm ³)	A	B	L	Mass (kg)
KWT2D-0.02	0.02×8	17.8	92.7	128.2	2.6	KWT2D-0.15	0.15×8	19.8	100.7	136.2	2.8
KWT2D-0.06	0.06×8	17.8	92.7	128.2	2.6	KWT2D-0.2	0.2×8	20.9	105.1	140.6	3
KWT2D-0.1	0.1×8	18.7	96.3	131.8	2.7	KWT2D-0.3	0.3×8	20.2	102.3	137.8	2.9

Parts List

Parts No.	Name	Q'ty/set
01	Front plate	1
02	Gear casing	4
03	Back plate	1
04	Middle plate	2
05	Middle plate	1
06	Arbor	1
07	Stud	4
08	Driving gear	4
09	Driven gear	8
10	Key	4
11	Seal housing	1
12	Oil seal	1
13	Gasket	1
14	Plate screw	6
15	Hub screw	3

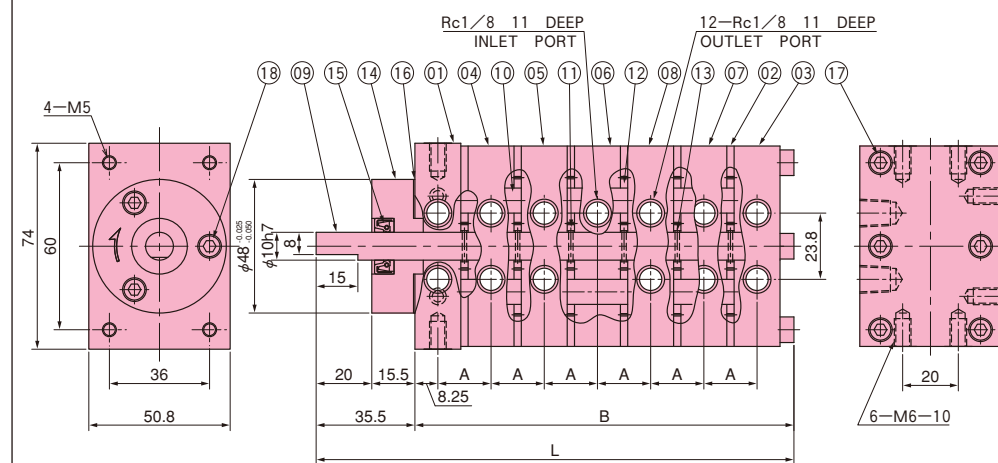

Model	Capacity (cm ³)	A	B	L	Mass (kg)	Model	Capacity (cm ³)	A	B	L	Mass (kg)
KWT3D-0.02	0.02×12	17.8	128.2	163.8	3.6	KWT3D-0.15	0.15×12	19.8	140.3	175.8	4.0
KWT3D-0.06	0.06×12	17.8	128.3	163.8	3.6	KWT3D-0.2	0.2×12	20.9	146.9	182.4	4.2
KWT3D-0.1	0.1×12	18.7	133.7	169.2	3.8	KWT3D-0.3	0.3×12	20.2	142.7	178.2	4.1

Parts List

Parts No.	Name	Q'ty/set
01	Front plate	1
02	Gear casing	6
03	Back plate	1
04	Middle plate	1
05	Middle plate	1
06	Middle plate	1
07	Middle plate	1
08	Middle plate	1
09	Arbor	1
10	Stud	6
11	Driving gear	6
12	Driven gear	12
13	Key	6
14	Seal housing	1
15	Oil seal	1
16	Gasket	1
17	Plate screw	6
18	Hub screw	3

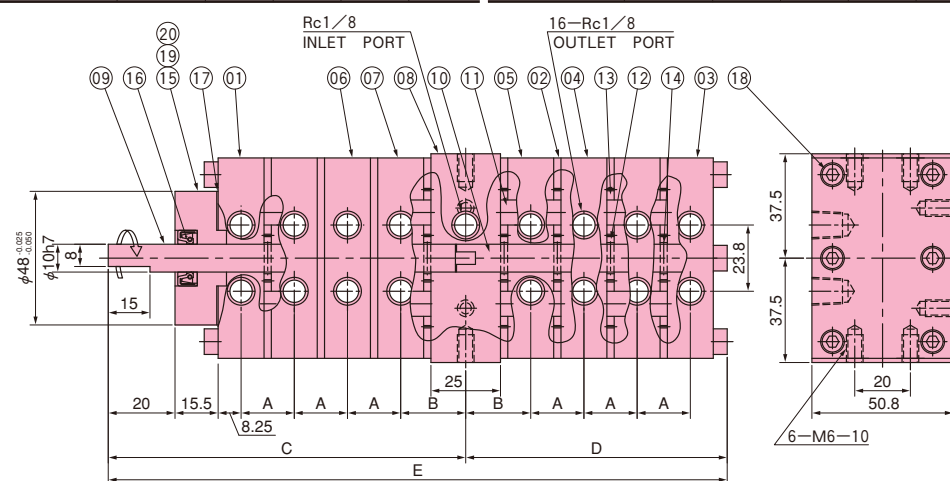

Model	Capacity (cm ³)	A	B	C	D	E	Mass (kg)
KWT4D-0.02	0.02×16	17.8	22.1	119.25	88.75	208	5
KWT4D-0.06	0.06×16	17.8	22.1	119.25	88.75	208	5
KWT4D-0.1	0.1×16	18.7	22.9	122.75	92.25	215	5.2
KWT4D-0.15	0.15×16	19.8	24	127.15	96.65	223.8	5.4
KWT4D-0.2	0.2×16	20.9	25.1	131.55	101.05	232.6	5.7
KWT4D-0.3	0.3×16	20.2	24.4	128.75	98.25	227	5.5

Parts List

Parts No.	Name	Q'ty/set
01	Front plate	1
02	Gear casing	8
03	Back plate	1
04	Middle plate	1
05	Middle plate	2
06	Middle plate	1
07	Middle plate	2
08	Wear plate	1
09	Arbor	1
10	Arbor	1
11	Stud	8
12	Driving gear	8
13	Driven gear	16
14	Key	8
15	Seal housing	1
16	Oil seal	1
17	Gasket	1
18	Plate screw	11
19	Plate screw	1
20	Hub screw	2

KXT2D/KXT3D/KXT4D SERIES

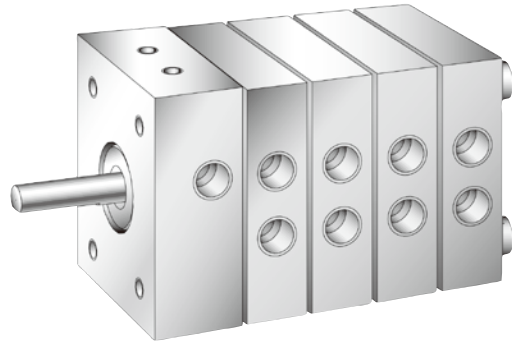

Main application : Spin-finish
 Number of ports : Inlet 1 ;
 Outlet

KXT2D	KXT3D	KXT4D
8	12	16

Displacement / port : 0.01 cm³
 Inlet pressure : 0 MPa~0.05 MPa (0 kgf/cm² ~ 0.5 kgf/cm²)
 Outlet pressure : Max. 0.05 MPa (Max. 0.5 kgf/cm²)
 Differential pressure : Max. 0.02 MPa (Max. 0.2 kgf/cm²)
 Temperature : Max. 50 °C
 Viscosity : Max. 50 mPa·s (Max. 50 C. Poise)
 Speed : 10 ~ 60 min⁻¹
 Standard material : Stainless steel
 Torque list :

	Bolt size	Torque	
		N·m	kgf·cm
For plates	M5	4.9~5.9	50~60
For hub	M5	4.9~5.9	50~60

STRUCTURE DIMENSIONS (mm)

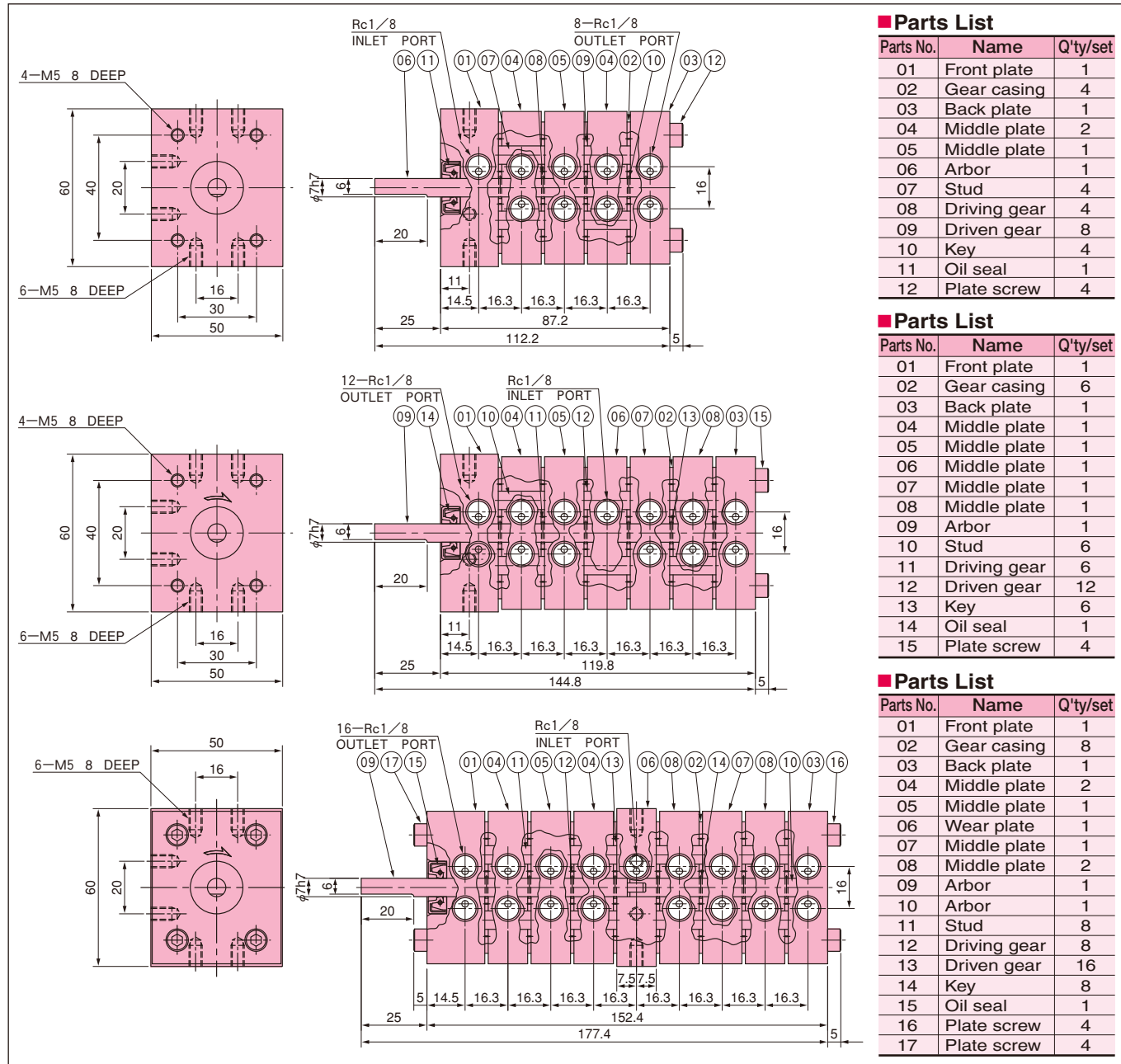

ZBD SERIES

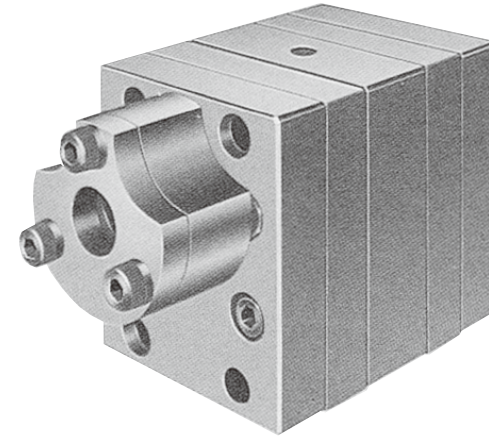

Main application : Melt-spinning
 Number of ports : Inlet 2 ; Outlet 2 (for conjugation)
 Displacement / port : 3 ~ 10 cm³
 Inlet pressure : 0.5 MPa ~ 19.6 MPa (5 kgf/cm² ~ 200 kgf/cm²)
 Outlet pressure : Max. 49.1 MPa (Max. 500 kgf/cm²)
 Differential pressure : Please refer to table as shown below.
 Temperature : Max. 350 °C
 Viscosity : Max. 400 Pa·s (Max. 4,000 Poise)
 Speed : 10 ~ 40 min⁻¹
 Standard material : Stainless steel
 Torque list :

	Bolt size	Torque	
		N·m	kgf·cm
For plates	M8	24.5~27.5	250~280
For hub	M8	24.5~27.5	250~280
For mounting	M10	49.1~53.9	500~550

STRUCTURE DIMENSIONS (mm)

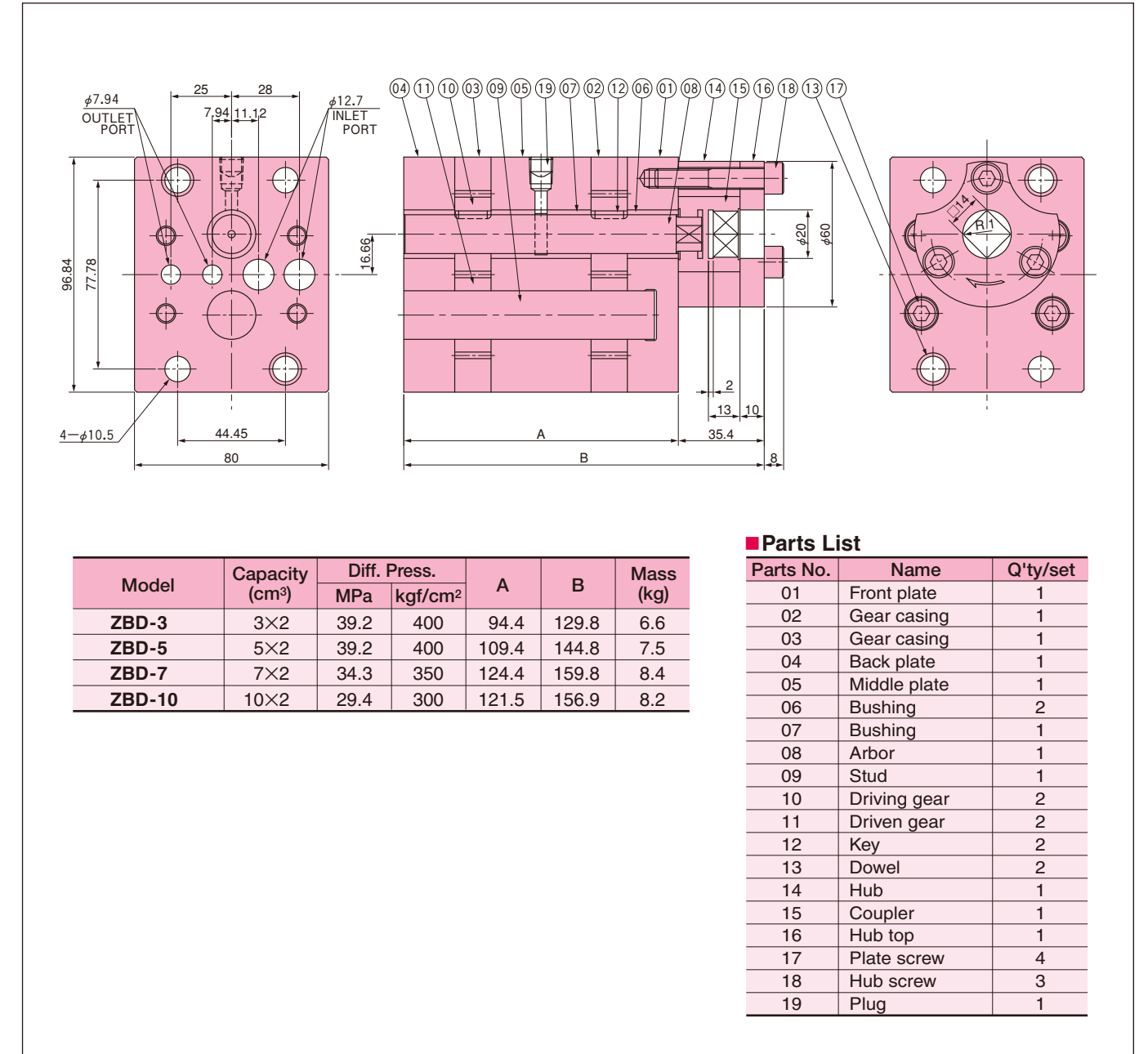

GDR SERIES

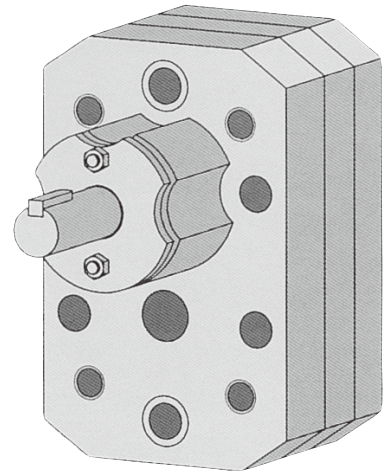

Main application : Miscellaneous, corrosive liquid
 Number of ports : Inlet 1 ; Outlet 1
 Displacement / port : 10 ~ 20 cm³
 Inlet pressure : 0.1 MPa ~ 2 MPa (1 kgf/cm² ~ 20 kgf/cm²)
 Outlet pressure : Max. 6.9 MPa (Max. 70 kgf/cm²)
 Differential pressure : Please refer to table as shown below.
 Temperature : Max. 120 °C
 Viscosity : Max. 100 Pa·s (Max. 1,000 Poise)
 Speed : 10 ~ 60 min⁻¹
 Standard material : Special corrosion-wear-resistant material
 Torque list :

	Bolt size	Torque	
		N·m	kgf·cm
For plates	1/2"–13 UNC(SUS304)	54 ~58.9	550~600
For hub	5/16"–18 UNC(SUS304)	10.8~12.3	110~125
For mounting	M12(SUS304)	44.1~47.1	450~480

STRUCTURE DIMENSIONS (mm)

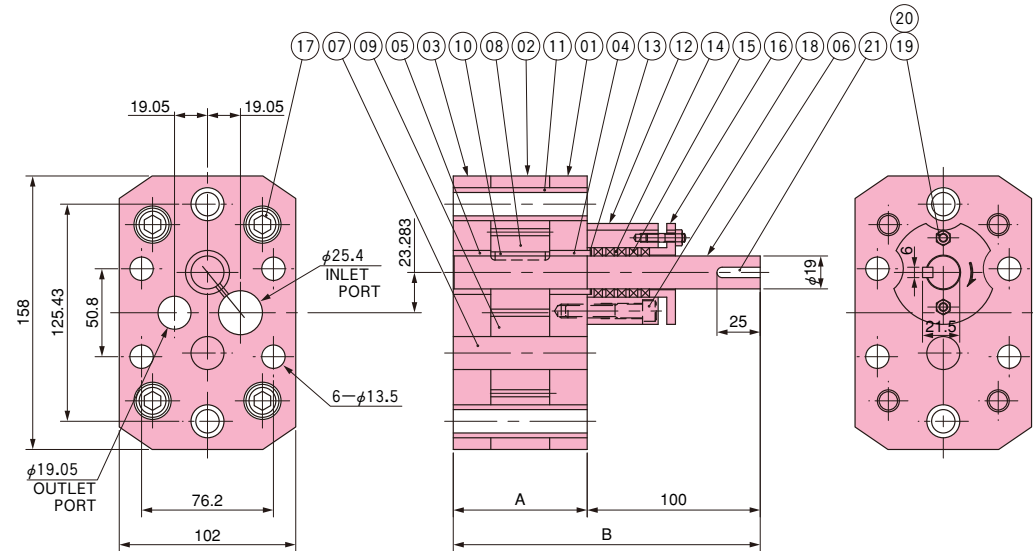

Model	Capacity (cm ³)	Diff. Press.		A	B	Mass (kg)
		MPa	kgf/cm ²			
GDR-10	10	4.9	50	60.4	160.4	7.6
GDR-15	15	4.9	50	69	169	8.8
GDR-20	20	4.9	50	77.4	177.4	9.9

Parts List

Parts No.	Name	Q'ty/set
01	Front plate	1
02	Gear casing	1
03	Back plate	1
04	Bushing	1
05	Bushing	1
06	Arbor	1
07	Stud	1
08	Driving gear	1
09	Driven gear	1
10	Key	1
11	Dowel	2
12	Hub	1
13	Spacer	1
14	Spacer	4
15	Gland packing	1
16	Retainer	1
17	Plate screw	4
18	Hub screw	4
19	Bolt	2
20	Nut	2
21	Key	1

KFS SERIES

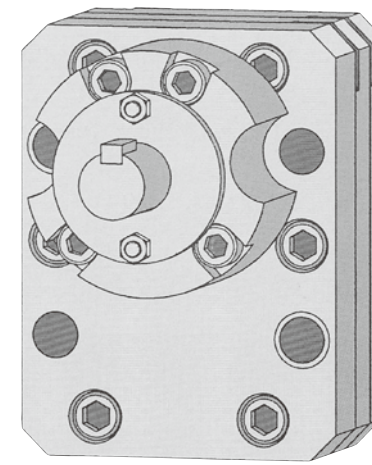

Main application : Miscellaneous, corrosive liquid
 Number of ports : Inlet 1 ; Outlet 1
 Displacement / port : 30 ~ 100 cm³
 Inlet pressure : 0.1 MPa ~ 2 MPa (1 kgf/cm² ~ 20 kgf/cm²)
 Outlet pressure : Max. 9.8 MPa (Max. 100 kgf/cm²)
 Differential pressure : Please refer to table as shown below.
 Temperature : Max. 120 °C
 Viscosity : Max. 100 Pa·s (Max. 1,000 Poise)
 Speed : 10 ~ 60 min⁻¹
 Standard material : Special corrosion-wear-resistant material
 Torque list :

	Bolt size	Torque	
		N·m	kgf·cm
For plates	M12(SUS304)	44.1~ 47.1	450~ 480
For hub	M10(SUS304)	24.5~ 27	250~ 275
For mounting	M16(SUS304)	112.8~122.6	1,150~1,250

STRUCTURE DIMENSIONS (mm)

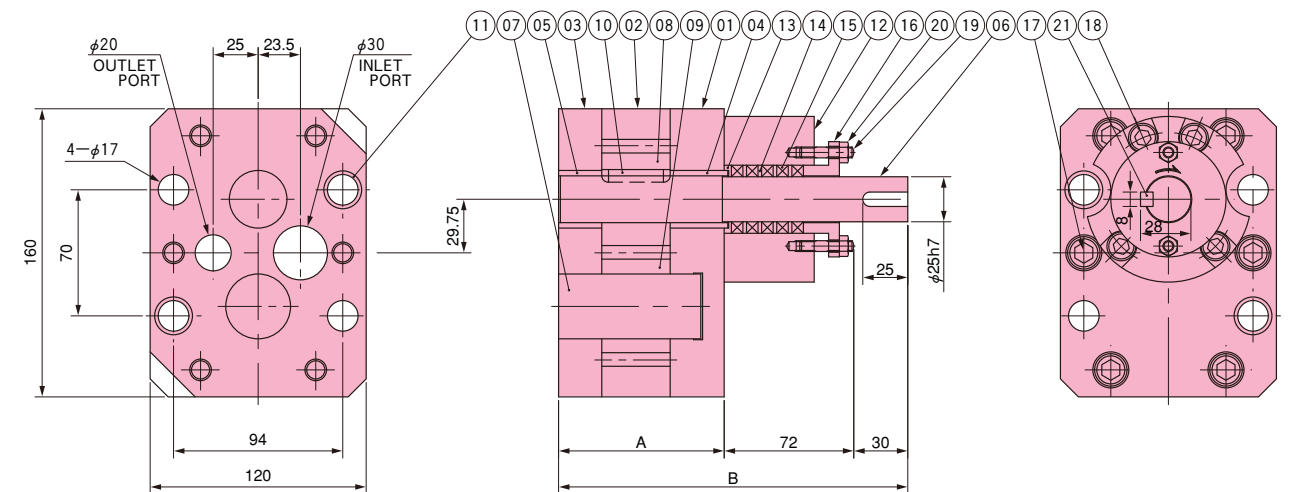

Model	Capacity (cm ³)	Diff. Press.		A	B	Mass (kg)
		MPa	kgf/cm ²			
KFS-30	30	6.9	70	76.5	178.5	11.8
KFS-40	40	6.9	70	84	186	12.9
KFS-50	50	6.9	70	92	194	14.1
KFS-60	60	6.9	70	99	201	15.2
KFS-80	80	4.9	50	114.4	216.4	17.6
KFS-100	100	4.9	50	129.5	231.5	19.9

Parts List

Parts No.	Name	Q'ty/set
01	Front plate	1
02	Gear casing	1
03	Back plate	1
04	Bushing	1
05	Bushing	1
06	Arbor	1
07	Stud	1
08	Driving gear	1
09	Driven gear	1
10	Key	1
11	Dowel	2
12	Hub	1
13	Spacer	1
14	Spacer	4
15	Gland packing	1
16	Retainer	1
17	Plate screw	6
18	Hub screw	4
19	Bolt	2
20	Nut	2
21	Key	1

PFS SERIES

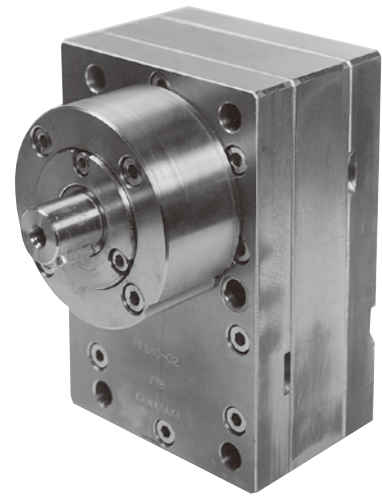

Main application : Miscellaneous, corrosive liquid
 Number of ports : Inlet 1 ; Outlet 1
 Displacement / port : 50 ~ 150 cm³
 Inlet pressure : 0.1 MPa ~ 2 MPa (1 kgf/cm² ~ 20 kgf/cm²)
 Outlet pressure : Max. 9.8 MPa (Max. 100 kgf/cm²)
 Differential pressure : Please refer to table as shown below.
 Temperature : Max. 120 °C
 Viscosity : Max. 100 Pa·s (Max. 1,000 Poise)
 Speed : 10 ~ 60 min⁻¹
 Standard material : Special corrosive-wear-resistant material
 Torque list :

	Bolt size	Torque	
		N·m	kgf·cm
For plates	M10(SUS304)	24.5 ~ 27	250 ~ 275
For hub	M8 (SUS304)	12.3 ~ 13.7	125 ~ 140
For mounting	M12(SUS304)	44.1 ~ 47.1	450 ~ 480

STRUCTURE DIMENSIONS (mm)

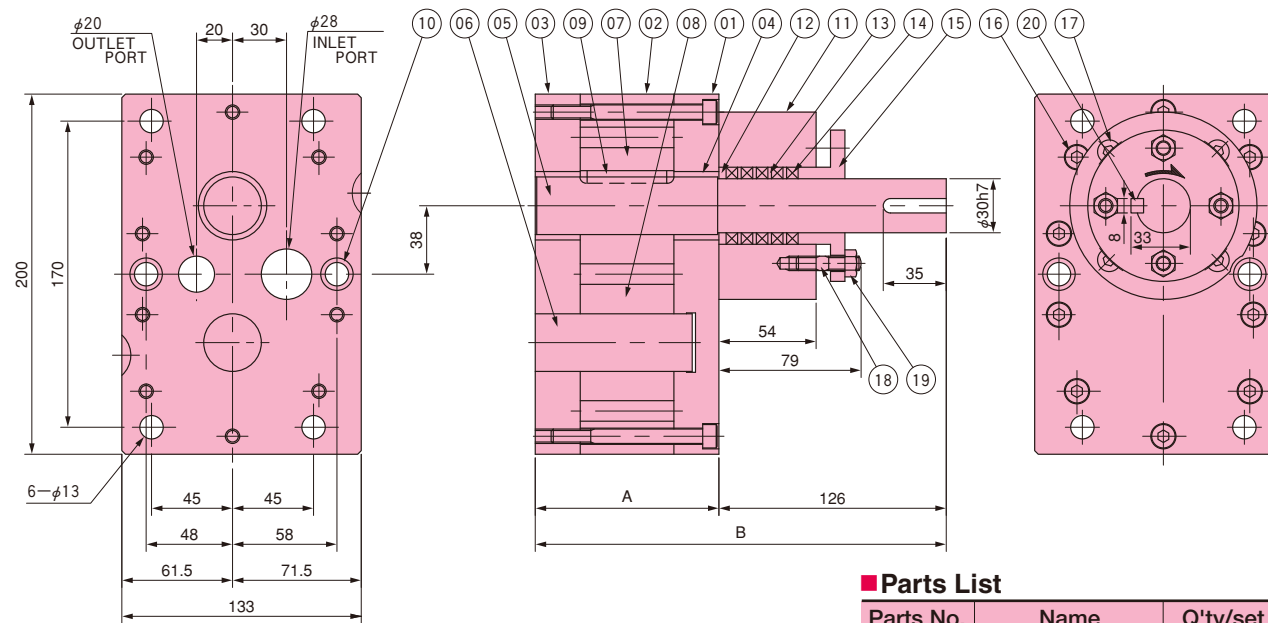

Parts List

Parts No.	Name	Q'ty/set
01	Front plate	1
02	Gear casing	1
03	Back plate	1
04	Bushing	2
05	Arbo	1
06	Stud	1
07	Driving gear	1
08	Driven gear	1
09	Key	1
10	Dowel	2
11	Hub	1
12	Spacer	1
13	Spacer	4
14	Gland packing	1
15	Retainer	1
16	Plate screw	10
17	Hub screw	4
18	Stud bolt	2
19	Nut	2

Model	Capacity (cm ³)	Diff. Press.		A	B	Mass (kg)
		MPa	kgf/cm ²			
PFS-50	50	7.8	80	76	206	15.8
PFS-80	80	7.8	80	91.5	221.5	19
PFS-100	100	4.9	50	102	232	21.2
PFS-150	150	4.9	50	128	258	26.6

HB SERIES

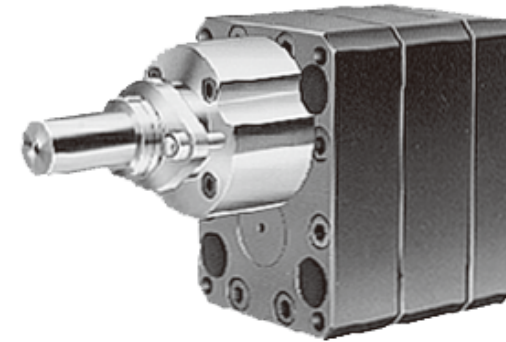

Main application : Polycondensation
 Number of ports : Inlet 1 ; Outlet 1
 Displacement / port : 200 ~ 1,500 cm³
 Inlet pressure : 0 MPa ~ 4.9 MPa (0 kgf/cm² ~ 50 kgf/cm²)
 Outlet pressure : Max. 29.4 MPa (Max. 300 kgf/cm²)
 Differential pressure : Max. 29.4 MPa (Max. 300 kgf/cm²)
 Temperature : Max. 350 °C
 Viscosity : Max. 5,000 Pa·s (Max. 50,000 Poise)
 Speed : 10 ~ 40 min⁻¹
 Standard material : Alloy tool steel
 Torque list :

Bolt size	Torque		Bolt size	Torque	
	N·m	kgf·m		N·m	kgf·m
M8	24.5 ~ 27.5	2.5 ~ 2.8	M20	382 ~ 412	39 ~ 42
M10	49.1 ~ 53.9	5.0 ~ 5.5	M24	677 ~ 686	69 ~ 70
M12	88.3 ~ 94.2	9.0 ~ 9.6	M30	1,275 ~ 1,285	130 ~ 131
M16	225 ~ 245	23 ~ 25			

STRUCTURE DIMENSIONS (mm)

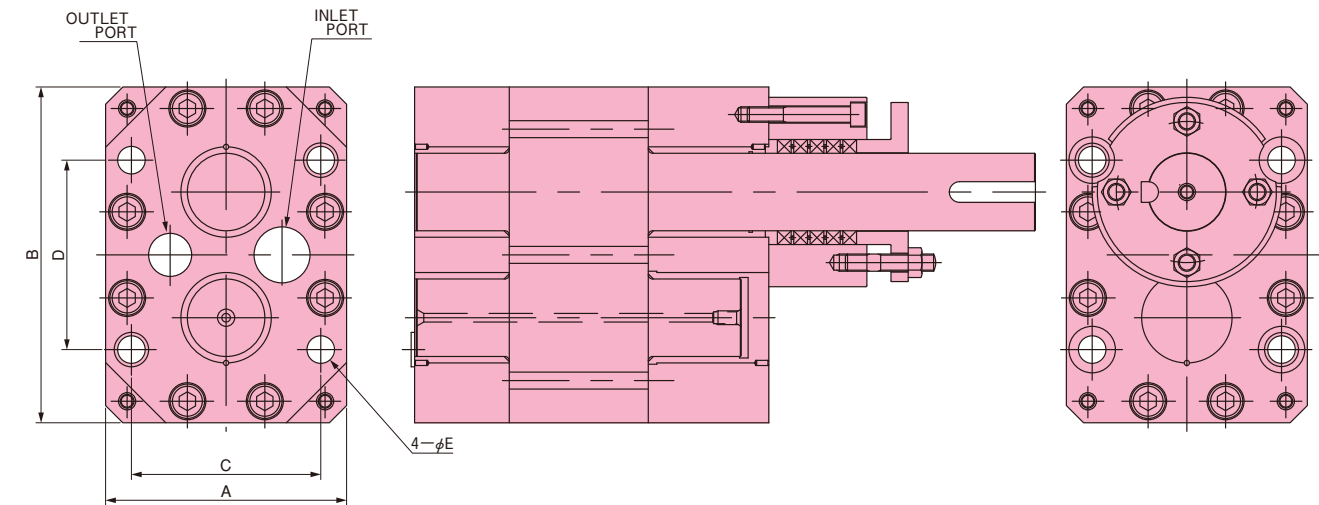

Model	Capacity (cm ³)	Dimension (mm)					Mass (kg)
		A	B	C	D	ØE	
HB-200	200	240	270	170	120	26	110
HB-300	300	240	270	170	120	26	125
HB-400	400	265	350	190	220	32	200
HB-500	500	265	350	190	220	32	210
HB-800	800	265	350	190	220	32	240
HB-1000	1,000	280	390	220	220	32	370
HB-1300	1,300	280	390	220	220	32	400
HB-1500	1,500	280	390	220	220	32	400

HT SERIES

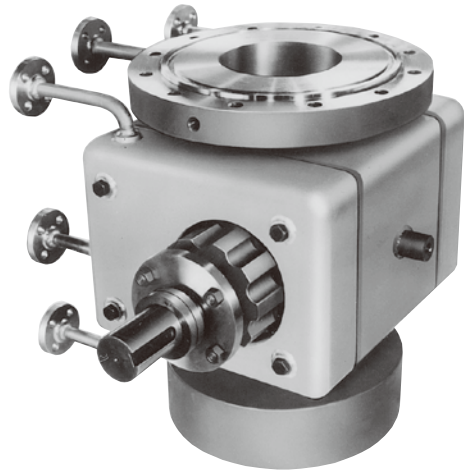

Main application : Vacuum discharge, polycondensation
 Number of ports : Inlet 1 ; Outlet 1
 Displacement / port : 10 ~ 5,000 cm³
 Inlet pressure : 0 MPa ~ 4.9 MPa (0 kgf/cm² ~ 50 kgf/cm²)
 Outlet pressure : Max. 29.4 MPa (Max. 300 kgf/cm²)
 Differential pressure : Max. 24.7 MPa (Max. 250 kgf/cm²)
 Temperature : Max. 350 °C
 Viscosity : Max. 10,000 Pa·s (Max. 100,000 Poise)
 Speed : 10 ~ 40 min⁻¹
 Standard material : Alloy tool steel

Torque list :

Bolt size	Torque		Bolt size	Torque	
	N·m	kgf·m		N·m	kgf·m
M8	24.5 ~ 27.5	2.5 ~ 2.8	M20	382 ~ 412	39 ~ 42
M10	49.0 ~ 53.9	5.0 ~ 5.5	M24	677 ~ 686	69 ~ 70
M12	88.3 ~ 94.1	9.0 ~ 9.6	M30	1,275 ~ 1,285	130 ~ 131
M16	225 ~ 245	23 ~ 25	M33	1,470 ~ 1,480	150 ~ 151

STRUCTURE DIMENSIONS (mm)

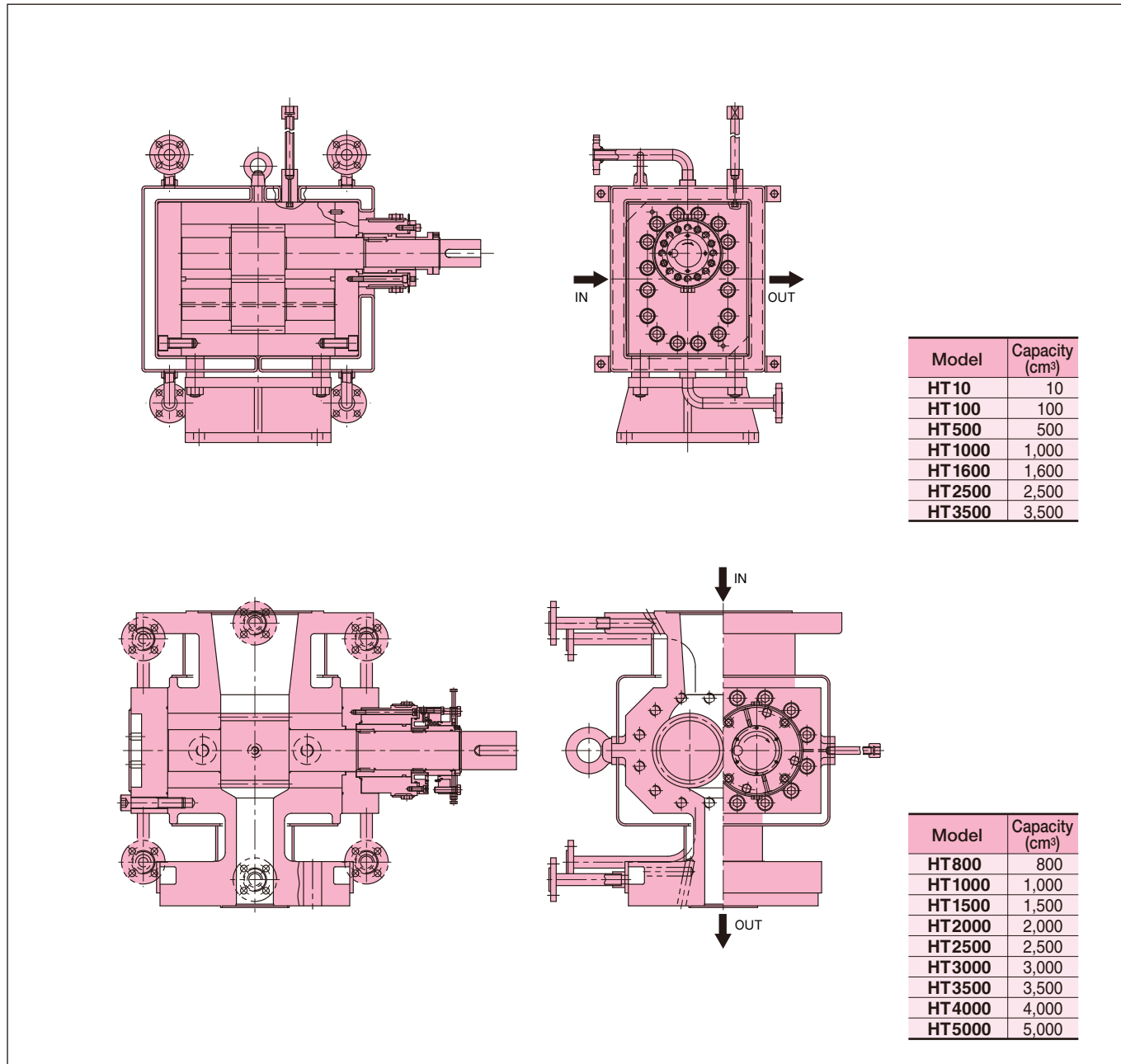

B SERIES

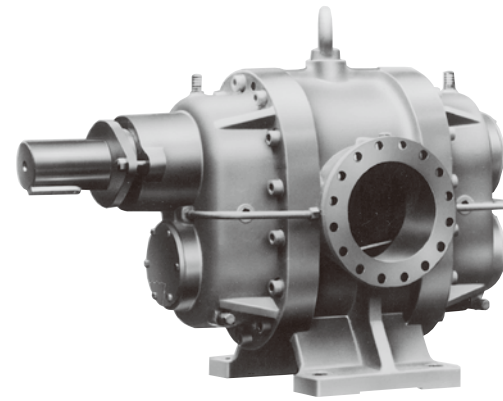

Main application : Pumping chemical fiber undiluted solution
 Number of ports : Inlet 1 ; Outlet 1
 Displacement / port : 300 ~ 40,000 cm³
 Inlet pressure : 0 MPa ~ 0.49 MPa (0 kgf/cm² ~ 5 kgf/cm²)
 Outlet pressure : Max. 4.9 MPa (Max. 50 kgf/cm²)
 Differential pressure : Max. 4.9 MPa (Max. 50 kgf/cm²)
 Temperature : Max. 120 °C
 Viscosity : Max. 200 Pa·s (Max. 2,000 Poise)
 Speed : Max. 80 min⁻¹
 Standard material : Stainless steel

Torque list :

Bolt size	Torque		Bolt size	Torque	
	N·m	kgf·m		N·m	kgf·m
M8	24.5 ~ 27.5	2.5 ~ 2.8	M20	382 ~ 412	39 ~ 42
M10	49.0 ~ 53.9	5.0 ~ 5.5	M24	677 ~ 686	69 ~ 70
M12	88.3 ~ 94.1	9.0 ~ 9.6	M30	1,275 ~ 1,285	130 ~ 131
M16	225 ~ 245	23 ~ 25			

STRUCTURE DIMENSIONS (mm)

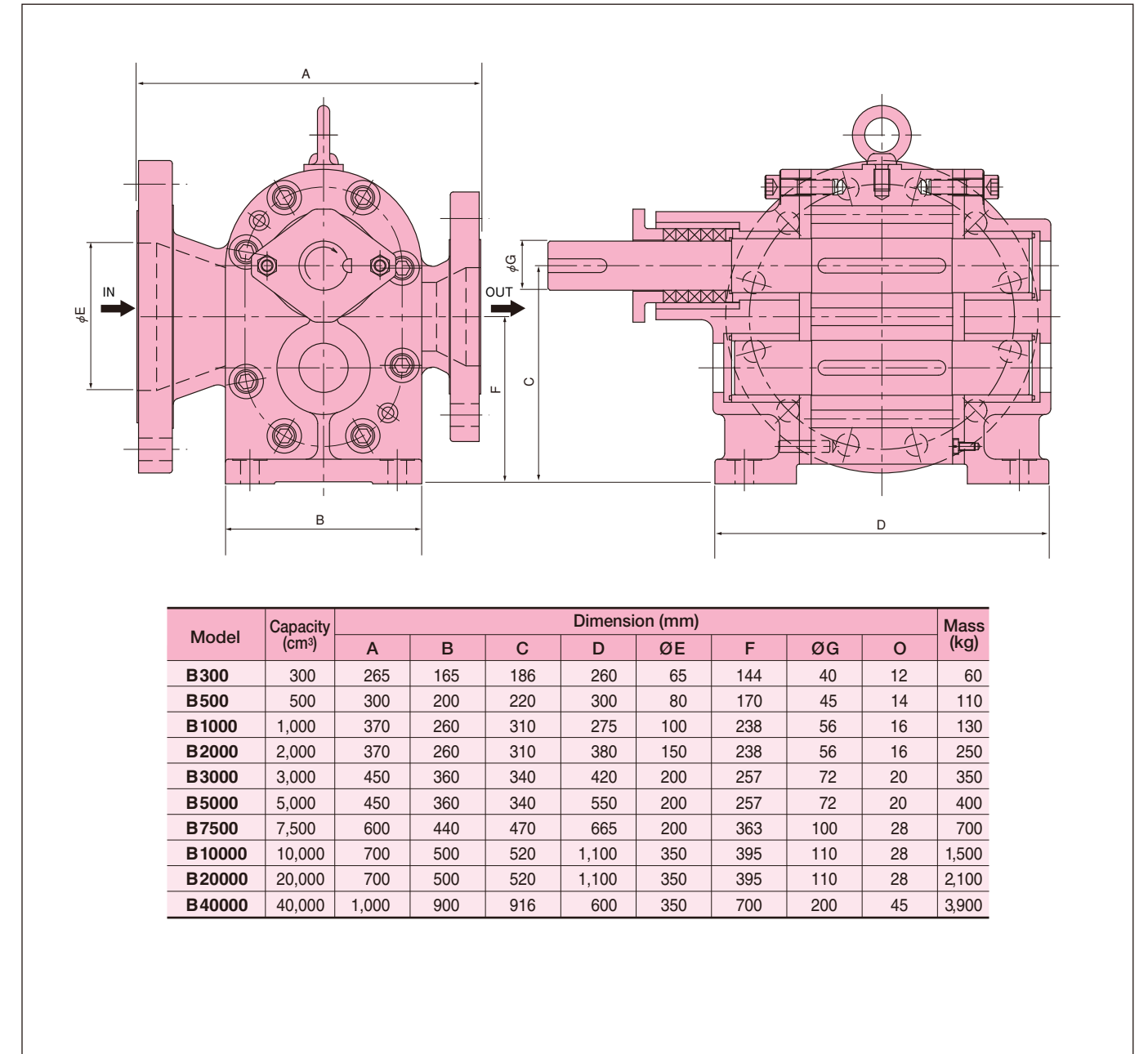

CAUTIONS FOR HANDLING

《Do》

1. GENERAL CAUTIONS

- Choose a suitable pump to meet the specifications.
- Be sure to read INSTRUCTION MANUAL before operation.
- To prevent hard particles or unmolten polymer from entering into the pump, select a clean location and/or place a filter at the pump inlet.
- Connect the piping properly. (Suction port is usually bigger than Delivery port.)
- To avoid leakage between the pump and the pump block, tighten all bolts to the torque specified.
Apply seizure-preventing oil to the threads of the mounting bolts (DAG#580, MoS₂, "Never-seaze", etc.)
- For sealing coupler type pumps:
 - ① Align the drive shaft end correctly to within 1° angle and within 0.1mm(0.004") of parallelness to the pump, and make sure it doesn't bottom in the slot of Coupler for proper function of the sealing mechanism.
 - ② Apply heat-resistant, non-evaporating lubricant (MoS₂, "Never-seaze", etc.) between Hub Top and Coupler to lubricate prior to polymer contact.
- Start the pump at the slowest speed.
- Make sure the rotational direction is to the arrow on the pump.
- For initial start or re-start after out of operation, be sure to check that the drive shaft turn smoothly by hand.
- Kawasaki Pumps are supplied with heat-resistant silicone oil inside for initial lubrication as well as for rust-preventing. When it is stored for a long time (6 months or more), apply silicone oil again and let oil prevail inside turning the shaft by hand.
- If the fluid tends to degrade or solidify during out of operation, it should be replaced with a stable agent. More preferably, dismantle the pump and dip in solvent, or disassemble and clean all the components. To store long, apply rust-preventing oil (Toray #710 silicone oil, effective for 6 months, etc.)
- Disassemble the pump and clean all the parts if the silicone oil is harmful to your application. On request, Kawasaki pumps are supplied with the specified liquid inside.
- Use an universal joint to drive for high temperature applications. For atmospheric temperature use, align the shaft to the values listed below.

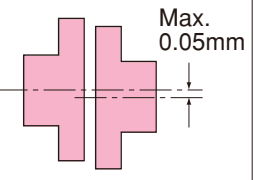
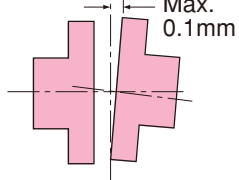
Parallel misalignment	Angular misalignment
	

- Use an electricity shut-off circuit for a drive motor, and also use a shear pin or a torque limiter to protect the pump in emergency.

《Don't》

- Don't operate the pump beyond the pressure, speed, and viscosity instructed in the specifications. It may seize or break by excessive outlet or inlet pressure in a moment.
- Don't feed such liquid as was used for cleaning a tank or pipe.
- Don't run the pump with no liquids inside. Dry-running may cause seizure on sliding parts.
- Don't pull from a vacuum or net negative suction head. Negative suction head causes cavitation, resulting in metering inaccuracy and seizure. (Contact us for negative suction head use)
- Don't run the pump reversely, because rotation direction is determined by design. Reverse rotation can not discharge liquid and cause breakage of the parts by excessive torque.
- Don't make a quick start. Quick start causes breakage of the shaft by excessive torque.
- Don't touch such rotating components as universal joint, shear pin coupling, torque limiter, etc.
- Don't feed liquid of temperature different from the pump body. Allowable temperature difference is Max.20 °C (Stainless steel or wear-resistant, corrosion-resistant material) or Max.50 °C (other materials)
- Never touch such high temperature objects as pump itself, heater, jacket, etc. to avoid a burn.
- Don't run the pump before it is raised to a operation temperature.
- Don't clean the pump at temperatures exceeding below.

Material	Temperature
SKD11	450 °C
SKH51	500 °C
SUS420J2/440C	150 °C

Contact us for other materials.

《Do》

2. CAUTIONS FOR HIGH TEMPERATURE APPLICATIONS

- Use an aluminum-cast or a plate heater for heating the pumps.
- Heating agents are also applicable when a jacketed special pump block is selected.
- Clean the mating faces of both the pump and pump block. Finish the mounting surface to flatness within 3μmRz convex and to smoothness within 0.4μmRz to avoid a polymer leak.
- Be sure to apply lubricants (heat resistant silicone oil) in the pump for initial lubrication, before heating the pump.
- Heat the pump at a rate of 100 °C/hour or slower. Heat uniformly. Turn the pump again by hand at the operation temperature to insure free rotation. To avoid a crack by thermal shock, preheat a pump to be installed on a hot pump block.

- Don't touch the heated aluminum-cast heater, plate heater or jacket to avoid a burn.
- Don't heat or cool the pump faster than 100 °C/hour. Quick heating or cooling causes a crack of the parts.
- Don't heat the pump locally. Ununiform heating causes a crack of the parts.

3. CAUTIONS FOR SADDLE-MOUNT, OTHER GEAR-DRIVEN PUMP

- Arrange tilt angle of the pump and rotation direction of the outer gear/drive gear as shown below. (a)
- The gears will disengage to protect the pump on excessive torque.
- Be sure to place a stopper to protect the pump in case of reverse rotation. (b)

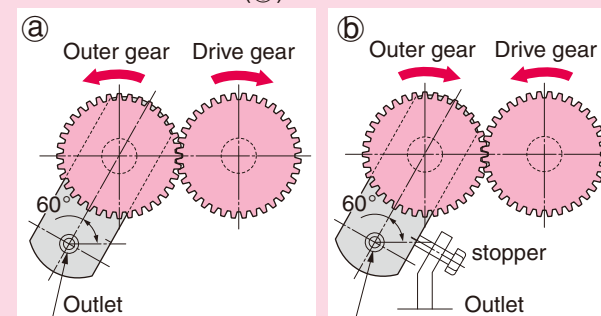

- Properly align the inlet/outlet trunnions and finish their spherical tips to 1.5μmRz or less in roughness.
- Clean the mating areas of both the pump and trunnions.
- Tighten the trunnions loosely first. Mesh the outer drive gear with the drive gear and give the drive gear several turns by hands to ensure free rotation. Tighten the trunnions securely to fix the pump to allow the backlash of around 0.1mm between the drive gears.
- Make sure there is fluid in the pump before starting. Minimum allowable pressure would be provided by a flooded inlet. For high viscosity fluid, apply positive inlet pressure before starting.
- Apply oil to the drive gears. (No oil required on plastic gears).

- Don't heat the pump over temperature of 150 °C. Heat uniformly and slowly (100 °C/hour or slower).
- Don't touch the outer gear or the drive gear while running.
- Don't engage or disengage the outer gear and the drive gear while the trunnions are tightened to avoid a damage on sealing surfaces.

4. CAUTIONS FOR SPIN-FINISH PUMP

- The pump should be directly coupled with a motor by a coupling.
- To prevent foreign substances from entering into the pump, place a filter of 10 micron meters or finer. The pump has very small clearances.
- Pump inlet side should be always flooded.

- Never drive the pump with a gear or a belt.

